



MCM280X

Modbus TCP/IP Remoted I/O



User manual / Manuale d'uso

Table of contents

1	Safety guidelines.....	5
1.1	Organization of safety notices.....	5
1.2	Safety Precautions.....	5
1.3	Precautions for safe use.....	5
1.4	Environmental policy / WEEE.....	6
2	Model identification.....	7
3	Dimension and installation.....	7
4	Technical data.....	7
4.1	General characteristics.....	7
4.2	Hardware characteristics.....	8
4.3	Electric connections.....	8
4.3.a	Power supply.....	9
4.3.b	Digital inputs.....	9
4.3.c	Digital outputs.....	9
4.3.d	Multifunction digital channels.....	9
4.3.e	Encoder/encounter inputs.....	9
4.3.f	Analogue inputs.....	10
4.3.g	Thermocouples.....	10
4.3.h	Thermoresistances.....	10
4.3.i	Analogue outputs.....	10
4.3.j	PTO outputs.....	10
4.3.k	Serial port COM1.....	10
4.3.l	Ethernet port.....	11
5	Operating specifications.....	11
5.1	General description.....	11
5.2	Parameters configuration.....	11
5.3	Modbus registers mapping.....	11
5.4	Meaning of the status lights (LED).....	17
5.4.1	I/Os Led.....	17
5.4.2	Hardware error Led.....	18
5.5	Firmware update.....	18
5.6	Factory settings reload.....	19
6	Functions.....	21
6.1	PWM's dynamic control.....	21
6.2	AO's control.....	22
6.3	Bridge mode.....	23
6.4	System offline.....	23
7	Control registers.....	24
7.1	Holding registers.....	24
7.2	Input registers.....	26
7.3	Coils.....	32
7.4	Discrete Inputs.....	32
8	Configuration parameters and registers.....	33
8.1	Holding registers.....	33
9	Configuring the device with MyPixsys Lab.....	43
9.1	Connection with the MCM280 module.....	43
9.2	Parameters configuration.....	45
9.3	Saving the device configuration.....	45
9.4	Loading device configuration from Backup file.....	46

Indice degli argomenti

1	Norme di sicurezza.....	48
1.1	Organizzazione delle note di sicurezza.....	48
1.2	Note di sicurezza.....	48
1.3	Precauzioni per l'uso sicuro.....	49
1.4	Tutela ambientale e smaltimento dei rifiuti / Direttiva WEEE.....	49
2	Identificazione del modello.....	50
3	Dimensioni e installazione.....	50
4	Dati tecnici.....	50
4.1	Caratteristiche generali.....	50
4.2	Caratteristiche Hardware.....	51
4.3	Collegamenti elettrici.....	51
4.3.a	Alimentazione.....	52
4.3.b	Ingressi digitali.....	52
4.3.c	Uscite digitali.....	52
4.3.d	Canali digitali multifunzione.....	52
4.3.e	Ingressi encoder/encounter.....	52
4.3.f	Ingressi analogici.....	53
4.3.g	Termocoppie.....	53
4.3.h	Termoresistenze.....	53
4.3.i	Uscite analogiche.....	53
4.3.j	Uscite PTO.....	53
4.3.k	Porta seriale COM1.....	53
4.3.l	Porta Ethernet.....	54
5	Specifiche di funzionamento.....	54
5.1	Descrizione generale.....	54
5.2	Configurazione dei parametri.....	54
5.3	Mappatura dei registri Modbus.....	54
5.4	Significato delle spie di stato (Led).....	60
5.4.1	Led I/O.....	60
5.4.2	Led di errore hardware.....	61
5.5	Aggiornamento firmware.....	61
5.6	Caricamento valori di default.....	62
6	Funzionalità.....	64
6.1	Controllo dinamico del PWM.....	64
6.2	Controllo dell'AO.....	65
6.3	Bridge mode.....	66
6.4	System offline.....	66
7	Registri di controllo.....	67
7.1	Holding registers.....	67
7.2	Input registers.....	69
7.3	Coils.....	75
7.4	Discrete Inputs.....	75
8	Parametri e registri di configurazione.....	76
8.1	Holding registers.....	76
9	Configurazione dispositivo con MyPixsys Lab.....	86
9.1	Connessione con il modulo MCM280.....	86
9.2	Configurazione dei parametri.....	88
9.3	Salvataggio della configurazione del dispositivo.....	88
9.4	Caricamento della configurazione del dispositivo da file di Backup.....	89

Introduction

Thank you for choosing a Pixsys device. The MCM280X module is a device that makes its hardware resources available via the Modbus TCP/IP protocol.

Configuration can be carried out using the appropriate Modbus TCP/IP registers or via the MyPixsys Lab application.

1 Safety guidelines

Read carefully the safety guidelines and programming instructions contained in this manual before connecting/using the device.

Disconnect power supply before proceeding to hardware settings or electrical wirings to avoid risk of electric shock, fire, malfunction.

Do not install/operate the device in environments with flammable/explosive gases.

This device has been designed and conceived for industrial environments and applications that rely on proper safety conditions in accordance with national and international regulations on labour and personal safety. Any application that might lead to serious physical damage/ life risk or involve medical life support devices should be avoided.

Device is not conceived for applications related to nuclear power plants, weapon systems, flight control, mass transportation systems.

Only qualified personnel should be allowed to use device and/or service it and only in accordance to technical data listed in this manual.

Do not dismantle/modify/repair any internal component.

Device must be installed and can operate only within the allowed environmental conditions. Overheating may lead to risk of fire and can shorten the lifecycle of electronic components.

1.1 Organization of safety notices

Safety notices in this manual are organized as follows:

Safety notice	Description
Danger!	Disregarding these safety guidelines and notices can be life-threatening.
Warning!	Disregarding these safety guidelines and notices can result in severe injury or substantial damage to property.
Information!	This information is important for preventing errors.

1.2 Safety Precautions

Danger!	CAUTION - Risk of Fire and Electric Shock This product is UL listed as DIN-rail mounting process control equipment. It must be mounted in an enclosure that does not allow fire to escape externally.
Warning!	Devices shall be supplied with limited energy according to UL 61010-1 3rd Ed, section 9.4 or LPS in conformance with UL 60950-1 or SELV in conformance with UL 60950-1 or Class 2 in compliance with UL 1310 or UL 1585.
Warning!	Loose screws may occasionally result in fire. For screw terminals, tighten screws to tightening torque is 0.5 Nm for 5 mm pitch terminal blocks or 0.25 Nm for 3.81 mm pitch terminal blocks.
Warning!	A malfunction in the device may occasionally make control operations impossible or prevent alarm outputs, resulting in property damage. To maintain safety in the event of malfunction of the device, take appropriate safety measures, such as installing a monitoring device on a separate line.

1.3 Precautions for safe use

Be sure to observe the following precautions to prevent operation failure, malfunction, or adverse affects on the performance and functions of the product. Not doing so may occasionally result in unexpected events. Do not handle the Digital Controller in ways that exceed the ratings.

- The product is designed for indoor use only. Do not use or store the product outdoors or in any of the following places.
 - Places directly subject to heat radiated from heating equipment.
 - Places subject to splashing liquid or oil atmosphere.
 - Places subject to direct sunlight.
 - Places subject to dust or corrosive gas (in particular, sulfide gas and ammonia gas).
 - Places subject to intense temperature change.
 - Places subject to icing and condensation.
 - Places subject to vibration and large shocks.
- Installing two or more controllers in close proximity might lead to increased internal temperature and this might shorten the life cycle of electronic components. It is strongly recommended to install cooling fans or other air-conditioning devices inside the control cabinet.
- Always check the terminal names and polarity and be sure to wire properly. Do not wire the terminals that are not used.
- To avoid inductive noise, keep the controller wiring away from power cables that carry high voltages or large currents. Also, do not wire power lines together with or parallel to Digital Controller wiring. Using shielded cables and using separate conduits or ducts is recommended. Attach a surge suppressor or noise filter to peripheral devices that generate noise (in particular motors, transformers, solenoids, magnetic coils or other equipment that have an inductance component). When a noise filter is used at the power supply, first check the voltage or current, and attach the noise filter as close as possible to the Digital Controller. Allow as much space as possible between the Digital Controller and devices that generate powerful high frequencies (high-frequency welders, high-frequency sewing machines, etc.) or surge.
- A switch or circuit breaker must be provided close to device. The switch or circuit breaker must be within easy reach of the operator, and must be marked as a disconnecting means for the controller.
- Wipe off any dirt from the Digital Controller with a soft dry cloth. Never use thinners, benzene, alcohol, or any cleaners that contain these or other organic solvents. Deformation or discoloration may occur.
- The number of non-volatile memory write operations is limited. Therefore, use EEPROM write mode when frequently overwriting data, e.g.: through communications.

1.4 Environmental policy / WEEE

Do not dispose electric tools together with household waste material.

According to European Directive 2012/19/EU on waste electrical and electronic equipment and its implementation in accordance with national law, electric tools that have reached the end of their life must be collected separately and returned to an environmentally compatible recycling facility.

2 Model identification

MCM280X-20AD	EXP/PLC 9 MODULES 161X90 - MODBUS TCP 8DI,8DO,8DI/O,4AI,2AO,2PTO,ETH,RS485
--------------	---

3 Dimension and installation

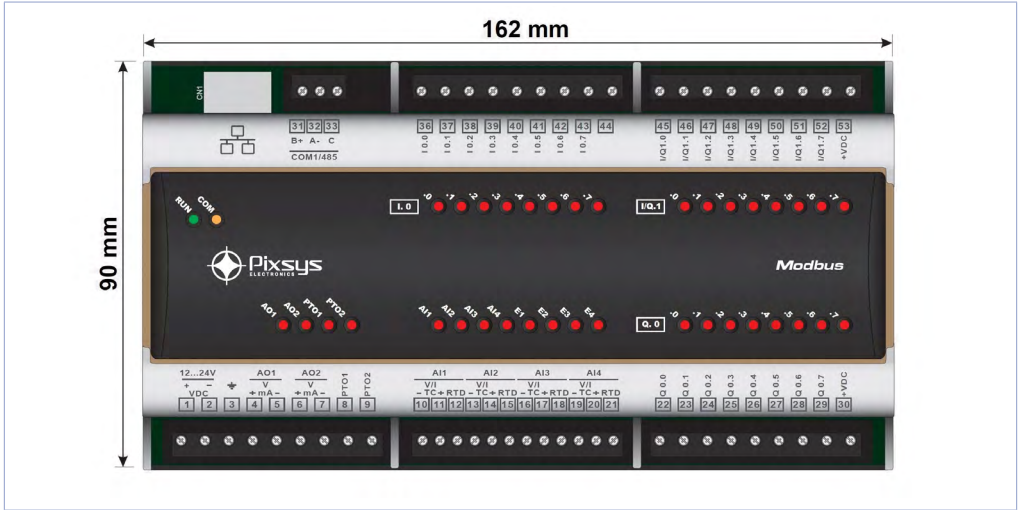

4 Technical data

4.1 General characteristics

Power supply	12..24 VDC \pm 10% Class2
Consumption	100W
Operating conditions	Temperature: 0-45 °C -Humidity 35..95 Rh% Max. altitude: 2000m
Protection	IP20 (container and blockings)
Materials	Front: self-extinguishing siliconic rubber V0
Weight	Approximately 380 g

4.2 Hardware characteristics

Digital inputs	8 PNP inputs 12-24Vdc (overlapped to digital outputs)	$V_{IL} = 4,4V$ $V_{IH} = 8,2V$
Digital outputs	8 static outputs 12-24Vdc	Max 700mA per output Max 2A total (Q.0.0-Q.0.7)
Multifunction digital channels	8 PNP 12-24 Vdc or PNP static 12-24 Vdc	Inputs: $V_{IL} = 4,4V$ $V_{IH} = 8,2V$ Outputs: Max 700mA per output Max 2A total (Q.1.0-Q.1.7)
Encoder/counter inputs	4 encoder/counter overlapped to PNP digital inputs	Resolution 32 bit Max frequency 100KHz
Analogue inputs	4 ingressi configurabili via software Termocoppie: tipo K, S, R, J, T, E, N, B; compensazione automatica del giunto freddo da 0..50°C. Termoresistenze: PT100, PT500, PT1000, Ni100, PTC1K, NTC10K (β 3435K) Ingresso V/I: 0-10V, 0-1V, 0-5V, 0-20mA, 4-20mA, 0-60mV. Potenziometri: 1..150K Ω	Galvanically isolated from power supply and communication port Resolution 16 bit Tolerance (25 °C) +/-0.2% \pm 1 digit (on F.s.)
Analogue outputs	2 uscite configurabili via software: 0-10V o 4-20mA	Resolution 16 bit
PTO outputs	2 uscite configurabili: ON/OFF, PWM, 12-24Vdc	Max: 20mA Max freq.: 200kHz
COM1 serial	1 \times RS485 with Modbus RTU protocol, with transparent Modbus TCP-RTU gateway/bridge function, maximum capacity 32 nodes.	
Ethernet port	1 port RJ45 Fast Ethernet 10/100 Mbit.	For parameter configuration via MyPixsys Lab PC software and programming from the LogicLab development environment, Modbus TCP/IP slave protocol.

4.3 Electric connections

Caution: This device was designed and built in compliance with the Electromagnetic compatibility 2014/30/UE (EMC) Directives.

For installation in industrial environments it is advisable to take the precautions below:

- Distinguish the power supply line from the power lines.
- Avoid proximity with contactor units, electromagnetic contactors, high power motors and use filters in any event.
- Avoid proximity with power units, particularly if with phase control.
- The use of network filters is recommended on the power supply of the machine in which the instrument will be installed, particular in case of 230Vac power supply.
The regulator is devised to be assembled with other machines. Therefore, the EC marking of the regulator does not exempt the manufacturer of the system from the safety and conformity obligations imposed for the machine as a whole.
- **Wiring of terminal block:** use crimped tube terminals or flexible/rigid copper wire with diameter between 0.15 and 1.5 mm² (min. AWG28, max. AWG16, operative temperature: min. 70°C). Cable stripping length max 7 mm.

4.3.a Power supply

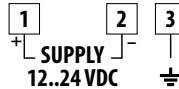
	<p>Power supply 12..24Vdc $\pm 10\%$</p> <ul style="list-style-type: none"> • 1: +Vdc • 2: -Vdc
---	--

4.3.b Digital inputs

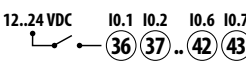
	<p>36: Input I0.0 37: Input I0.1 38: Input I0.2 39: Input I0.3 40: Input I0.4 41: Input I0.5 42: Input I0.6 43: Input I0.7</p>
--	---

4.3.c Digital outputs

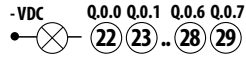
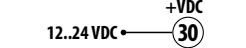
	<p>22: Output Q0.0 23: Output Q0.1 24: Output Q0.2 25: Output Q0.3 26: Output Q0.4 27: Output Q0.5 28: Output Q0.6 29: Output Q0.7</p>
	<p>Digital outputs power supply Q0.0 -Q0.7</p>

4.3.d Multifunction digital channels

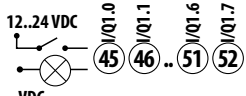
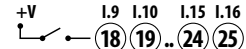
	<p>45: Input/Output I/Q1.0 46: Input/Output I/Q1.1 47: Input/Output I/Q1.2 48: Input/Output I/Q1.3 49: Input/Output I/Q1.4 50: Input/Output I/Q1.5 51: Input/Output I/Q1.6 52: Input/Output I/Q1.7</p>
	<p>Digital outputs power supply Q1.0 -Q1.7</p>

4.3.e Encoder/encounter inputs

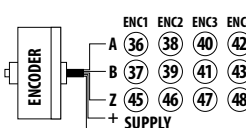
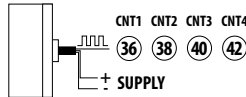
	<p>Push-Pull Encoder Use only push-pull encoders Maximum frequency 100kHz</p>
	<p>Counter PNP inputs Maximum frequency 100kHz</p>

4.3.f Analogue inputs

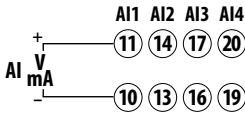

Signals in tension 0..10V, 0..1V, 0..5V, 0..60mV
 Signals in current 0..20 mA, 4..20mA

4.3.g Thermocouples

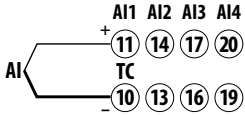

Analog inputs for thermocouples K, S, R, J, T, E, N, B.

- Respect the polarity
- To avoid extensions use a compensating cable and clips that suit the thermocouple used (compensating)

4.3.h Thermoresistances

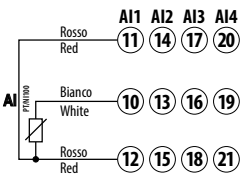

Analog inputs for resistance thermometers PT100, Ni100.

- For the three wire connection use cables with the same section
- For the two wire connection short circuit clips 11 and 12 (AI1), 14 and 15 (AI2), 17 and 18 (AI3), 20 and 21 (AI4).

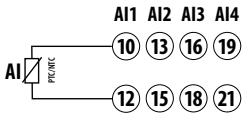
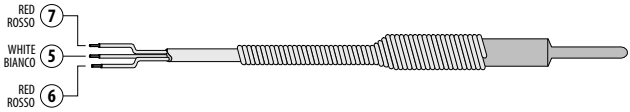

Analog inputs for resistance thermometers NTC, PTC, PT500, PT1000 and linear potentiometers.

4.3.i Analogue outputs

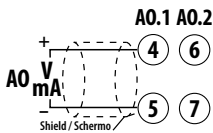

Configurable:

0-10 V with 30000 points $\pm 0.3\%$ (on F.S.) 25 °C;

load $\geq 1 \text{ K}\Omega$

4-20 mA con 25000 points $\pm 0.3\%$ (on F.S.) 25 °C;

load $\leq 500\Omega$

4.3.j PTO outputs

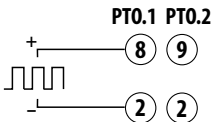

Configurable:

ON/OFF: activation in ON/OFF mode as digital output

PWM: PWM output with variable frequency and duty cycle

Connect the PTO outputs with reference to 0V on terminal 2.

4.3.k Serial port COM1

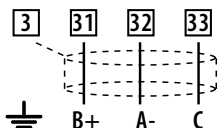

31: (B+) RS485+

32: (A-) RS485-

33: (C) Reference

Connect the cable screen, if any, to terminal 3.

4.3.1 Ethernet port

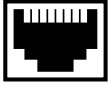

Connector type: RJ45 (female). 10/100 Mbit Ethernet port for parameter configuration and network connectivity

5 Operating specifications

5.1 General description

The **MCM280X** module is a **Modbus TCP/IP** remote I/O equipped with **Bridge** functionality, which allows communication with other devices connected to the serial port via **Modbus RTU**. The Modbus memory is structured to simplify module configuration and use; some registers are duplicated to increase versatility and operational flexibility.

5.2 Parameters configuration

When first started up, the device is always configured with the default parameters. Each time new configuration parameters are set, it will be necessary to switch the device off and on again, or restart it. Each time the system is started, the saved parameters are read, and the MCM configures Modbus communication with the last configuration set.

The parameters can be set by:

- writing the relevant Modbus TCP/IP registers (default 192.168.0.175, slave ID 247)
- writing with the Mypixsys Lab desktop application

5.3 Modbus registers mapping

List of predefined registers for accessing and using integrated hardware resources.

Holding register	Name	Access
0	En/Status PTO Outputs	R/W
1	Value AO1	R/W
2	Value AO2	R/W
3	Commands Encoder 1	R/W
4	Commands Encoder 2	R/W
5	Commands Encoder 3	R/W
6	Commands Encoder 4	R/W
11	Frequency PWM PTO1 L	R/W
12	Frequency PWM PTO1 H	R/W
13	Frequency PWM PTO2 L	R/W
14	Frequency PWM PTO2 H	R/W
15	Duty Cycle PTO1	R/W
16	Duty Cycle PTO2	R/W
17	Commands PTO1	R/W
18	Commands PTO2	R/W
19	Digital Output bit mask	R/W
54	Frequency PWM PTO1 H (BIS)	R/W
55	Frequency PWM PTO1 L (BIS)	R/W
56	Frequency PWM PTO2 H (BIS)	R/W
57	Frequency PWM PTO2 L (BIS)	R/W
100	Offline Counter	R/W
501	RTU Baudrate	R/W
502	RTU frame format	R/W

Holding register	Name	Access
503	RTU time-out	R/W
504	RTU slave id	R/W
505	DHCP enable	R/W
506	Modbus port	R/W
507	Bridge enable	R/W
510	IP address part 1	R/W
511	IP address part 2	R/W
512	IP address part 3	R/W
513	IP address part 4	R/W
514	Subnet mask part 1	R/W
515	Subnet mask part 2	R/W
516	Subnet mask part 3	R/W
517	Subnet mask part 4	R/W
518	Gateway part 1	R/W
519	Gateway part 2	R/W
520	Gateway part 3	R/W
521	Gateway part 4	R/W
522	Dns part 1	R/W
523	Dns part 2	R/W
524	Dns part 3	R/W
525	Dns part 4	R/W
526	Enable idle timeout	R/W
527	TCP/IP server timeout	R/W
528	Time between messages	R/W
530	Device name characters 1 - 2	R/W
531	Device name characters 3 - 4	R/W
532	Device name characters 5 - 6	R/W
533	Device name characters 7 - 8	R/W
534	Device name characters 9 - 10	R/W
535	Device name characters 11 - 12	R/W
536	Device name characters 13 - 14	R/W
537	Device name characters 15 - 16	R/W
538	Device name characters 17 - 18	R/W
539	Device name characters 19 - 20	R/W
540	Device name characters 21 - 22	R/W
541	Device name characters 23 - 24	R/W
542	Offline timeout	R/W
543	Offline outputs bitmask	R/W
544	Enable offline	R/W
545	Offline AO1 value	R/W
546	Offline AO2 value	R/W
550	Sensor type AI1	R/W
551	Sensor type AI2	R/W
552	Sensor type AI3	R/W
553	Sensor type AI4	R/W
554	Temperature Unit Setting	R/W
555	Lower limit AI1	R/W

Holding register	Name	Access
556	Lower limit AI2	R/W
557	Lower limit AI3	R/W
558	Lower limit AI4	R/W
559	Upper limit AI1	R/W
560	Upper limit AI2	R/W
561	Upper limit AI3	R/W
562	Upper limit AI4	R/W
563	Potentiometer value AI1	R/W
564	Potentiometer value AI2	R/W
565	Potentiometer value AI3	R/W
566	Potentiometer value AI4	R/W
567	Linear overrange limit AI1	R/W
568	Linear overrange limit AI2	R/W
569	Linear overrange limit AI3	R/W
570	Linear overrange limit AI4	R/W
571	Offset calibration AI1	R/W
572	Offset calibration AI2	R/W
573	Offset calibration AI3	R/W
574	Offset calibration AI4	R/W
575	Gain calibration AI1	R/W
576	Gain calibration AI2	R/W
577	Gain calibration AI3	R/W
578	Gain calibration AI4	R/W
579	Filter AI1	R/W
580	Filter AI2	R/W
581	Filter AI3	R/W
582	Filter AI4	R/W
583	Maximum Acceptable Delta AI1	R/W
584	Maximum Acceptable Delta AI2	R/W
585	Maximum Acceptable Delta AI3	R/W
586	Maximum Acceptable Delta AI4	R/W
587	Maximum Rejection Time AI1	R/W
588	Maximum Rejection Time AI2	R/W
589	Maximum Rejection Time AI3	R/W
590	Maximum Rejection Time AI4	R/W
591	Sampling Frequency AI1 AI2	R/W
592	Sampling Frequency AI3 AI4	R/W
593	Digital input filter	R/W
594	Encoder/Counter type 1	R/W
595	Encoder/Counter type 2	R/W
596	Encoder/Counter type 3	R/W
597	Encoder/Counter type 4	R/W
598	Encoder preset 1 L	R/W
599	Encoder preset 1 H	R/W
600	Encoder preset 2 L	R/W
601	Encoder preset 2 H	R/W
602	Encoder preset 3 L	R/W

Holding register	Name	Access
603	Encoder preset 3 H	R/W
604	Encoder preset 4 L	R/W
605	Encoder preset 4 H	R/W
606	Type AO1	R/W
607	Type AO2	R/W
608	Lower limit AO1	R/W
609	Lower limit AO2	R/W
610	Upper limit AO1	R/W
611	Upper limit AO2	R/W
612	Error value AO1	R/W
613	Error value AO2	R/W
614	PTO1 output type	R/W
615	PTO2 output type	R/W
700	Encoder preset 1 H (BIS)	R/W
701	Encoder preset 1 L (BIS)	R/W
702	Encoder preset 2 H (BIS)	R/W
703	Encoder preset 2 L (BIS)	R/W
704	Encoder preset 3 H (BIS)	R/W
705	Encoder preset 3 L (BIS)	R/W
706	Encoder preset 4 H (BIS)	R/W
707	Encoder preset 4 L (BIS)	R/W

Input register	Name	Access
0	Value Ohm AI1	R
1	Value Ohm AI2	R
2	Value Ohm AI3	R
3	Value Ohm AI4	R
4	Encoder counter 1 L	R
5	Encoder counter 1 H	R
6	Encoder counter 2 L	R
7	Encoder counter 2 H	R
8	Encoder counter 3 L	R
9	Encoder counter 3 H	R
10	Encoder counter 4 L	R
11	Encoder counter 4 H	R
12	Encoder counter (1 s) 1 L	R
13	Encoder counter (1 s) 1 H	R
14	Encoder counter (1 s) 2 L	R
15	Encoder counter (1 s) 2 H	R
16	Encoder counter (1 s) 3 L	R
17	Encoder counter (1 s) 3 H	R
18	Encoder counter (1 s) 4 L	R
19	Encoder counter (1 s) 4 H	R
20	Encoder counter (100 ms) 1 L	R
21	Encoder counter (100 ms) 1 H	R
22	Encoder counter (100 ms) 2 L	R
23	Encoder counter (100 ms) 2 H	R

Input register	Name	Access
24	Encoder counter (100 ms) 3 L	R
25	Encoder counter (100 ms) 3 H	R
26	Encoder counter (100 ms) 4 L	R
27	Encoder counter (100 ms) 4 H	R
32	Value AI1	R
33	Value AI2	R
34	Value AI3	R
35	Value AI4	R
36	Error Flags	R
37	Cold junction 1 temperature	R
38	Cold junction 2 temperature	R
39	PWM running status PTO1	R
40	PWM running status PTO2	R
41	Digital inputs	R
100	Conversion AI1 L	R
101	Conversion AI1 H	R
102	Conversion AI2 L	R
103	Conversion AI2 H	R
104	Conversion AI3 L	R
105	Conversion AI3 H	R
106	Conversion AI4 L	R
107	Conversion AI4H	R
108	Conversion average AI1 L	R
109	Conversion average AI1 H	R
110	Conversion average AI2 L	R
111	Conversion average AI2 H	R
112	Conversion average AI3 L	R
113	Conversion average AI3 H	R
114	Conversion average AI4 L	R
115	Conversion average AI4H	R
150	Encoder counter 1 H (BIS)	R
151	Encoder counter 1 L (BIS)	R
152	Encoder counter 2 H (BIS)	R
153	Encoder counter 2 L (BIS)	R
154	Encoder counter 3 H (BIS)	R
155	Encoder counter 3 L (BIS)	R
156	Encoder counter 4 H (BIS)	R
157	Encoder counter 4 L (BIS)	R
158	Encoder counter (1 s) 1 H (BIS)	R
159	Encoder counter (1 s) 1 L (BIS)	R
160	Encoder counter (1 s) 2 H (BIS)	R
161	Encoder counter (1 s) 2 L (BIS)	R
162	Encoder counter (1 s) 3 H (BIS)	R
163	Encoder counter (1 s) 3 L (BIS)	R
164	Encoder counter (1 s) 4 H (BIS)	R
165	Encoder counter (1 s) 4 L (BIS)	R
166	Encoder counter (100 ms) 1 H (BIS)	R



















Input register	Name	Access
167	Encoder counter (100 ms) 1 L (BIS)	R
168	Encoder counter (100 ms) 2 H (BIS)	R
169	Encoder counter (100 ms) 2 L (BIS)	R
170	Encoder counter (100 ms) 3 H (BIS)	R
171	Encoder counter (100 ms) 3 L (BIS)	R
172	Encoder counter (100 ms) 4 H (BIS)	R
173	Encoder counter (100 ms) 4 L (BIS)	R
501	Active connections	R
502	Valid answers	R
503	CRC errors counter	R
504	Exception errors counter	R
505	TCP/IP connection errors counter	R
506	TCP/IP timeout errors counter	R

Coils	Name	Access
0	Digital Output Q 0.0	R/W
1	Digital Output Q 0.1	R/W
2	Digital Output Q 0.2	R/W
3	Digital Output Q 0.3	R/W
4	Digital Output Q 0.4	R/W
5	Digital Output Q 0.5	R/W
6	Digital Output Q 0.6	R/W
7	Digital Output Q 0.7	R/W
8	Digital Output I/Q 1.0	R/W
9	Digital Output I/Q 1.1	R/W
10	Digital Output I/Q 1.2	R/W
11	Digital Output I/Q 1.3	R/W
12	Digital Output I/Q 1.4	R/W
13	Digital Output I/Q 1.5	R/W
14	Digital Output I/Q 1.6	R/W
15	Digital Output I/Q 1.7	R/W

Discrete Inputs	Name	Access
0	Digital Input I 0.0	R
1	Digital Input I 0.1	R
2	Digital Input I 0.2	R
3	Digital Input I 0.3	R
4	Digital Input I 0.4	R
5	Digital Input I 0.5	R
6	Digital Input I 0.6	R
7	Digital Input I 0.7	R
8	Digital Input I/Q 1.0	R
9	Digital Input I/Q 1.1	R
10	Digital Input I/Q 1.2	R
11	Digital Input I/Q 1.3	R
12	Digital Input I/Q 1.4	R



13	Digital Input I/Q 1.5	R
14	Digital Input I/Q 1.6	R
15	Digital Input I/Q 1.7	R

5.4 Meaning of the status lights (LED)

LED RUN	LED COM	Status	Communication
 BLINKING 10Hz		Initialisation error, no initialisation	No communication
 BLINKING 1Hz		Offline error	Any communication
		Waiting for connection	No communication
		Modbus TCP/IP active	Active Modbus TCP/IP communication
	 BLINKING	Modbus RTU active	Active Modbus RTU communication
 BLINKING		Memory reading/writing	Communication with MYPISYS LAB
		Modbus TCP/IP active, with communication errors, impossible to connect to remote server	Modbus TCP/IP communication in error
	 BLINKING	Modbus RTU active, with communication errors	Modbus RTU communication in error
 BLINKING 1Hz		Initialising communication with the remote server/ Firmware update	HTTPS communication in error

5.4.1 I/Os Led



LED AOx	Status
	Analog Output active
	Analog Output not active

LED PTOx	Status
	PTO Output/PWM active
	PTO Output/PWM not active

LED AIx	Status
	Input signal
 BLINKING	Input error, input configuration error or damaged probe
	No signal detected





















































LED Q.x	Status
	Digital Output active
	Digital Output not active

LED I.x	Status
	Input signal
	No signal detected

LED I/Q.x	Status
	Input signal / Digital Output active
	No signal detected / Digital Output not active

LED CONFIRM	Status
	Pressed button
 BLINKING	Default parameters loaded

5.4.2 Hardware error Led

LED E1	LED E2	LED E3	LED E4	Err. code	Descriptione
				0	No error
				1	Parameters error, unable to load parameters from memory
				2	Status error, unable to load status data from memory
				3	Calibration error, unable to load calibration data from memory
				4	Constants error, unable to load constant data from memory
				5	Calibration error none, I/O calibrations not present
				6	EOut of Range error, parameter out of range
				7	Memory error, hardware error on I/O parameter memory
				8	Cold junction error, cold junction break
				9	Errore power supply, tensione di alimentazione troppo bassa
				10	Errore memory, errore hardware su memoria parametri
				11	Ethernet error, unable to configure communication port
				12	Error on integrated I/O

5.5 Firmware update

To update the device firmware to the latest version available:

- connect the device to an Ethernet network with a DHCP server and Internet access, or correctly configure the DNS and GATEWAY addresses to access the Internet
- if using a DHCP network, set the DHCP enable parameter to YES
- start the update procedure by pressing the Update button in the Utilities menu.

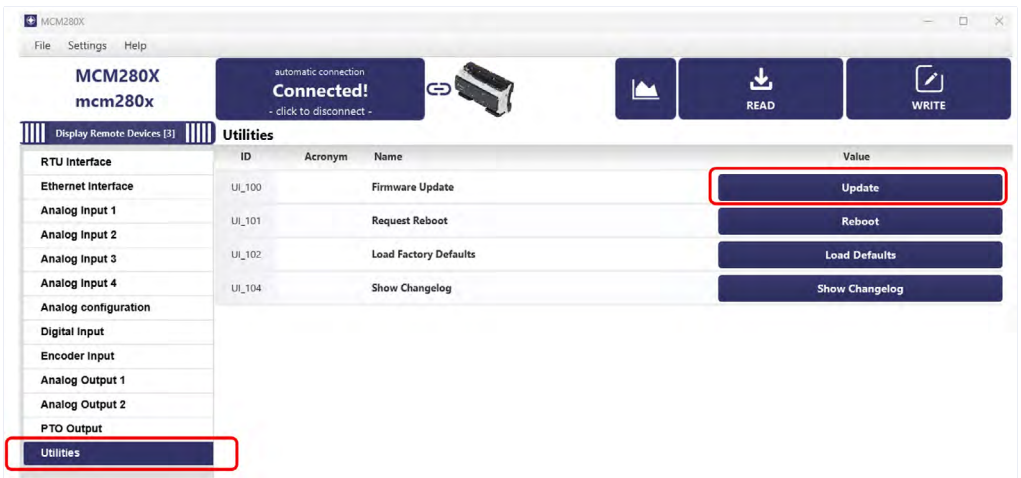

5.6 Factory settings reload

If you need to reset the module to factory settings, follow the procedure below.



- Switch on the MCM280X module.
- Open the front cover.
- Press and hold the S1 button (located at the bottom left of the card under the cover) for at least 10 seconds.
- When the reset is complete, the green CONFIRM led will flash.
- Release S1 button.
- Switch the MCM280X module off and then on again.

The factory settings are as follows:

Parameter	Factory setting value
RTU Baudrate	115200
RTU frame format	data: 8 bits stop: 1 bit parity: none
RTU time-out	100
RTU slave id	247
DHCP enable	NO
Modbus port	502
Bridge enable	NO
IP address	192.168.0.175
Subnet mask	255.255.0.0
Gateway	0.0.0.0
Dns	0.0.0.0
Enable idle timeout	NO
TCP/IP server timeout	0
Time between messages	0
Device name characters	mcm280

Parameter	Factory setting value
Offline timeout	0
Offline outputs bitmask	0
Enable offline	NO
Offline AO1 value	0
Offline AO2 value	0
Sensor type AI1	Disable
Sensor type AI2	Disable
Sensor type AI3	Disable
Sensor type AI4	Disable
Temperature Unit Setting	°C
Lower limit AI1	0
Lower limit AI2	0
Lower limit AI3	0
Lower limit AI4	0
Upper limit AI1	1000
Upper limit AI2	1000
Upper limit AI3	1000
Upper limit AI4	1000
Potentiometer value AI1	10 kΩ
Potentiometer value AI2	10 kΩ
Potentiometer value AI3	10 kΩ
Potentiometer value AI4	10 kΩ
Linear overrange limit AI1	OFF
Linear overrange limit AI2	OFF
Linear overrange limit AI3	OFF
Linear overrange limit AI4	OFF
Offset calibration AI1	0
Offset calibration AI2	0
Offset calibration AI3	0
Offset calibration AI4	0
Gain calibration AI1	0.0
Gain calibration AI2	0.0
Gain calibration AI3	0.0
Gain calibration AI4	0.0
Filter AI1	10
Filter AI2	10
Filter AI3	10
Filter AI4	10
Maximum Acceptable Delta AI1	10.0
Maximum Acceptable Delta AI2	10.0
Maximum Acceptable Delta AI3	10.0
Maximum Acceptable Delta AI4	10.0
Maximum Rejection Time AI1	1.0
Maximum Rejection Time AI2	1.0
Maximum Rejection Time AI3	1.0
Maximum Rejection Time AI4	1.0
Sampling Frequency AI1 AI2	17 Hz
Sampling Frequency AI3 AI4	17 Hz
Digital input filter	5 ms
Encoder/Counter type 1	Disable
Encoder/Counter type 2	Disable
Encoder/Counter type 3	Disable

Parameter	Factory setting value
Encoder/Counter type 4	Disable
Encoder preset 1	0
Encoder preset 2	0
Encoder preset 3	0
Encoder preset 4	0
Type AO1	0 - 10V
Type AO2	0 - 10V
Lower limit AO1	0
Lower limit AO2	0
Upper limit AO1	1000
Upper limit AO2	1000
Error value AO1	0
Error value AO2	0
PTO1 output type	ON/OFF
PTO2 output type	ON/OFF

6 Functions

6.1 PWM's dynamic control

To use dynamic control of PTO outputs in PWM mode, you must configure the output by selecting **PWM** mode in the **PTOx Output Mode** parameter.

By setting the **Start PWM Dynamic Control** command in the **Commands PTOx** register, the output generates a square wave with:

- Frequency equal to the value of the **Frequency PWM PTOx** register
- Duty Cycle equal to the value of the **Duty Cycle PTOx** register.

Once the output has been activated, the PWM values can be modified in real time by updating the dedicated registers. This allows the output signal to be controlled dynamically, for example to generate acceleration or deceleration ramps.

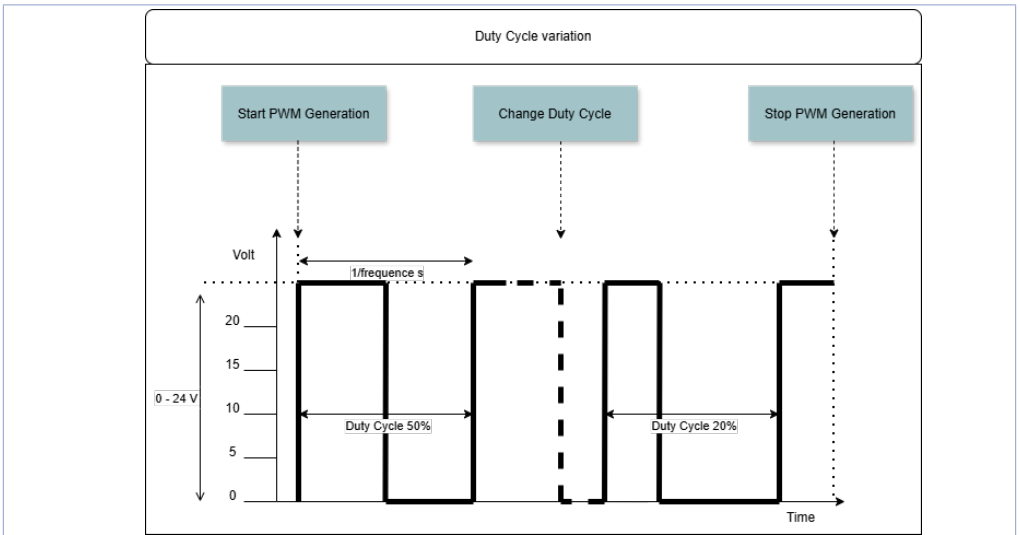

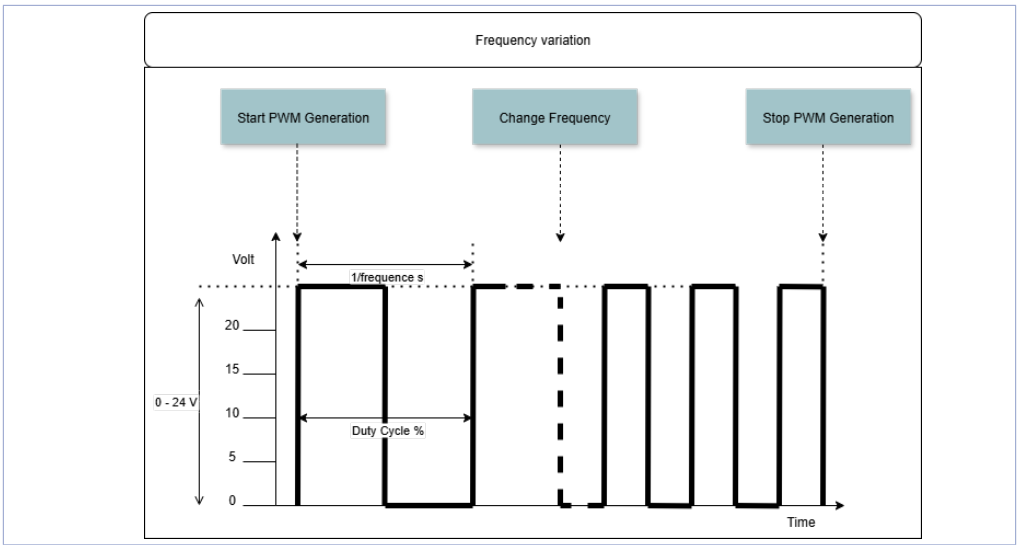

6.2 AO's control

To control the AO outputs, you must configure the **Lower limit AOx**, **Upper limit AOx**, and **Error value AOx** parameters.

After configuring the output, write to the corresponding **Value AOx** register.

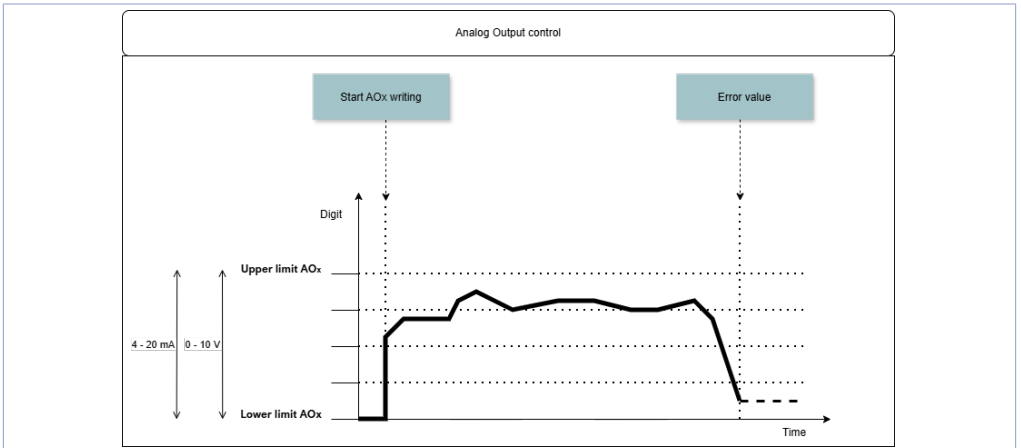

6.3 Bridge mode

In Bridge mode, the module acts as Modbus TCP/IP ports with all slaves connected.

To use Bridge mode, the Bridge enable parameter must be set to ON.

After restarting the module, connect the Modbus RTU slaves to COM1.

To communicate with the slaves, simply query the registers at the IP address of the MCM280 with the Modbus ID of the slaves.

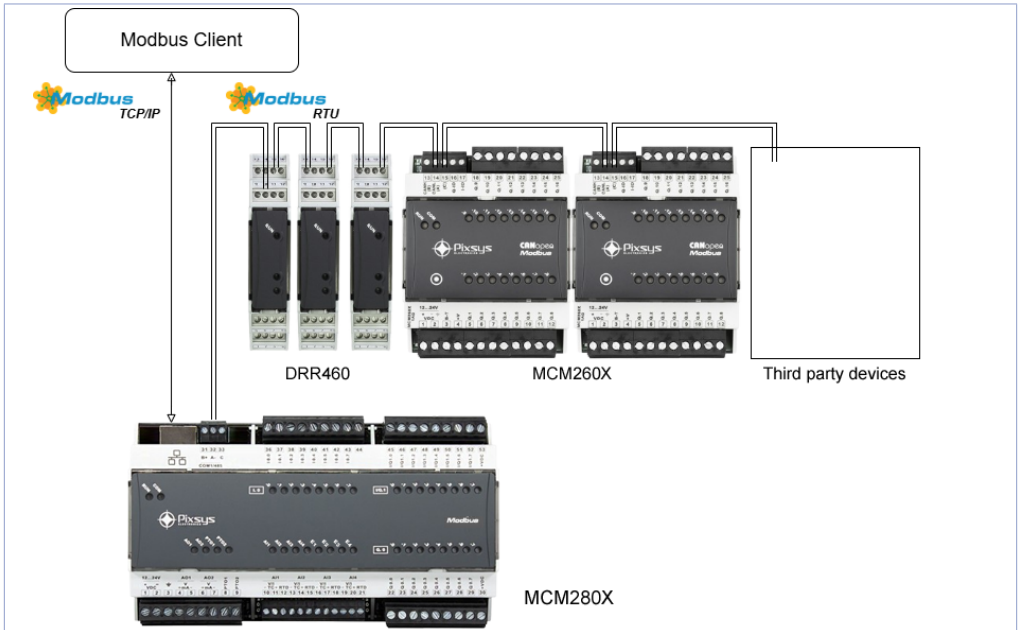

6.4 System offline

This operating mode does NOT replace the mandatory electrical safety measures, nor does it, in itself, constitute a safety system. Using the device without adequate precautions, safeguards and checks in accordance with the regulatory requirements for electrical and machine safety may pose risks to people and equipment.

To use the Offline feature, you must configure the following settings:

- Offline Timeout
 - Offline Outputs Bitmask
 - Offline AO1 value
 - Offline AO2 value
 - Enable Offline
- If the value of the Offline Timeout parameter is greater than zero and the Enable Offline parameter is set to YES, System Offline is enabled.

The Offline System is activated upon the first Modbus TCP/IP connection. From that point onwards, the system periodically checks for changes in the value of the Offline counter register (Holding Register 100).

- If the contents of the register do not change within the configured timeout period, the system detects an offline condition and activates the digital and analogue outputs as defined by the parameter Offline Outputs Bitmask, Offline AO1 value, Offline AO2 value

The outputs retain the set status until a new change in value is detected in the Offline counter register. Following this change, the output status check will become available again.

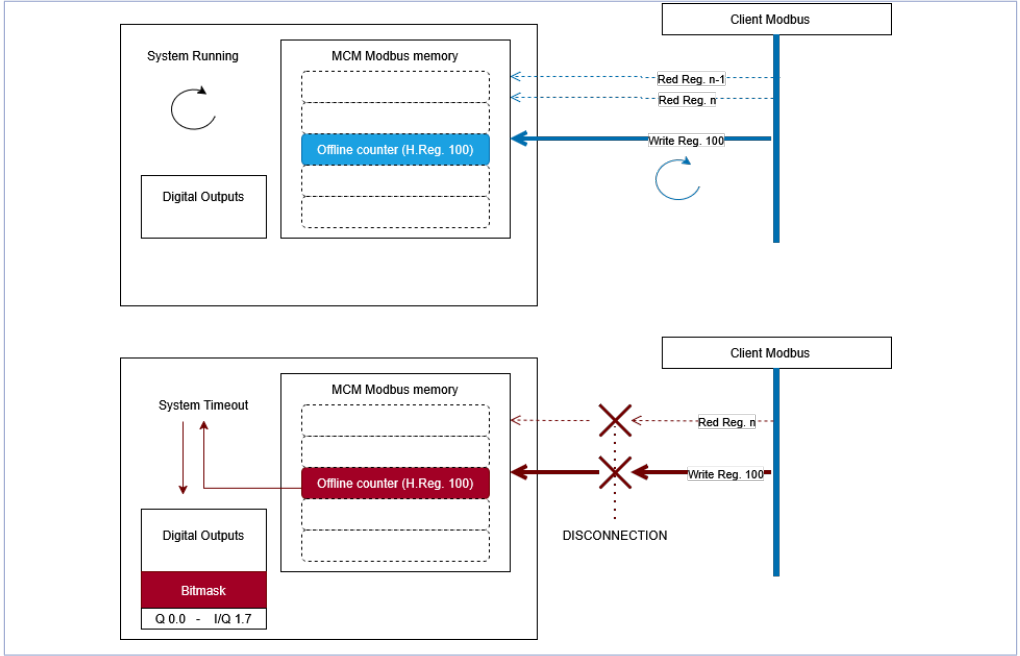

7 Control registers

7.1 Holding registers

Address: -0

Default
0

Values' range
0 - 2

En/Status PTO Outputs

Description

Bit mask to control PTO outputs in ON/OFF mode. If the outputs are set as PWM, it communicates the active status of the outputs. (see **PTO1 output mode**, **PTO2 output mode** parameters)

BIT0: PTO1
BIT1: PTO2

Address: -1 -2

Default
0

Values' range
Lower limit AO1 - Upper limit AO1
or
Lower limit AO2 - Upper limit AO2

Value AOx

Description

Control value of analogue output AOx. Based on the **AOx mode** configuration parameter, it can be configured to operate in **0-10 Volt** or **4-20mA** mode. The value generated by the output in the event of an error or anomaly can be set using the **Error value AOx** parameter.

Address: -3 -4 -5 -6**Commands Encoder x****Default**

0

Values' range

Lower limit AO1 - Upper limit AO1

0

Lower limit AO2 - Upper limit AO2

DescriptionBit mask for sending commands to the **Encoder x**.

The bits are automatically loaded with a value of zero after the command is executed.

BIT0: Load preset value**BIT1:** Load preset value during next Z pulseThe **preset** value is set to the **Encoder preset x** parameter.**Address: -11 -12 -13 -14****Frequency PWM PTOx****Default**

2000

Values' range [Hz]

1 - 20000

DescriptionValue of the square wave frequency generated by the **PTOx** output when configured as **PWM**.(see parameter **PTO1 output mode** or **PTO2 output mode**)**PTO1****Low part:** register 11**High part:** register 12**PTO2****Low part:** register 13**High part:** register 14**Address: -15 -16****Duty Cycle PTOx****Default**

50.00

Values' range [%]

0.00 - 100.00

DescriptionDuty cycle value of the square wave generated by the **PTOx** output when configured as **PWM**(see **PTO1 output mode** or **PTO2 output mode** parameter)**Address: -17 -18****Commands PTOx****Default**

0

Values' range

10 - 11

DescriptionCommands to activate and deactivate the **PTOx** output in **PWM** mode**10:** Start PWM Dynamic control**11:** Stop PWM**Address: -19****Digital output****Default**

0

Values' range

0 - 65535

Description

Bit mask for controlling digital outputs

BIT0: Q.0.0**BIT1:** Q.0.1

...

BIT8: Q.1.0**BIT9:** Q.1.1

Address: -54 -55 -56 -57

Frequency PWM PTOx (BIS)

Default

1

Description

Copy of the **Frequency PWM PTOx** registers but with the word order reversed

Values' range [digit]

1 - 20000

PTO1

Low part: register 55

High part: register 54

PTO2

Low part: register 57

High part: register 56

Address: -100

Offline counter

Default

0

Description

If the **Offline Timeout** parameter is greater than 0, and **Enable offline** is set to YES, the system periodically checks for changes in the value of this register following the first Modbus TCP/IP connection. If the value remains unchanged for longer than the set timeout, an offline condition is detected and the outputs are forced in accordance with the **Offline Outputs Bitmask**, **Offline AO1 value**, **Offline AO2 value** parameter setting. For further details, please refer to the section 6.4 System Offline.

Values' range

1 - 65535

7.2 Input registers

Address: -0 -1 -2 -3

Value Ohm Alx

Default

-

Description

Ohm value of the analogue input in the case of NI, PT, NTC, PTC sensors, potentiometers

Values' range

0 - 65535

Address: -4 -5 -6 -7

Encoder counter x

-8 -9 -10 -11

Default

-

Description

Encoder/counter count represented as a 32-bit value.

Values' range

0 - 4294967295

Encoder 1

Low part: register 4

High part: register 5

Encoder 2

Low part: register 6

High part: register 7

Encoder 3

Low part: register 8

High part: register 9

Encoder 4

Low part: register 10

High part: register 11

Address: -12 -13 -14 -15
-16 -17 -18 -19

Encoder counter (1 s) x

Default

-

Values' range

0 - 4294967295

Description

Encoder/counter count represented as a 32-bit value. Data updated every 1.0 s.

Encoder 1

Low part: register 12

High part: register 13

Encoder 2

Low part: register 14

High part: register 15

Encoder 3

Low part: register 16

High part: register 17

Encoder 4

Low part: register 18

High part: register 19

Address: -20 -21 -22 -23
-24 -25 -26 -27

Encoder counter (100 ms) x

Default

-

Values' range

0 - 4294967295

Description

Encoder/counter count represented as a 32-bit value. Data updated every 100 ms.

Encoder 1

Low part: register 20

High part: register 21

Encoder 2

Low part: register 22

High part: register 23

Encoder 3

Low part: register 24

High part: register 25

Encoder 4

Low part: register 26

High part: register 27

Address: -32 -33 -34 -35

Value Alx

Default

-

Values' range

-32768 - +32768

Description

Value of analogue inputs.

In the case of configuration with temperature sensors, the value is expressed in tenths of a degree.

In the event of error conditions :

- input out of range,
- short circuit,
- open circuit,

the specific error codes provided by the system will be returned.

Short: -32768

Open 32767

For Alx out-of-range errors, refer to the **Error Flags** register.

In the event of an error on the inputs, the corresponding LEDs will signal the error as described in Tables 7.4.1 I/O LEDs.

Address: -36

Error Flags

Default

-

Values' range

0 - 65535

Description

Hardware error flags related to I/O

BIT0: Parameters error, unable to load parameters from memory

BIT1: Status error, unable to load status data from memory

BIT2: Calibration error, unable to load calibration data from memory

BIT3: Constants error, unable to load constant data from memory

BIT4: Calibration error none, I/O calibrations not present

BIT5: Out of Range error, parameter out of range

BIT6: Memory error, hardware error on I/O parameter memory

BIT7: Cold junction error, cold junction break

BIT8: Power supply error, supply voltage too low

BIT9: AI1 out of range

BIT10: AI2 out of range

BIT11: AI3 out of range

BIT12: AI4 out of range

Address: -37 -38

Cold junction temp x

Default

-

Values' range

0 - 65535

Description

Temperature detected by the cold junction.

Used for error compensation for correct absolute temperature reading.

Address: -39 -40

PWM running status PTOx

Default

-

Description

PTO output status

Values' range

0 - 1

0: PWM OFF

1: PWM running

Address: -41

Digital Inputs

Default

-

Description

Bit mask for reading digital inputs

Values' range

0 - 65535

BIT0: I.0.0

BIT1: I.0.1

...

BIT8: I.1.0

BIT9: I.1.1

Address: -100 -101 -102 -103
-104 -105 -106 -107

Conversion Alx

Default

-

Description

Converted analogue signal

Values' range

0 - 4294967295

AI1

Low part: register 100

High part: register 101

AI2

Low part: register 102

High part: register 103

AI3

Low part: register 104

High part: register 105

AI4

Low part: register 106

High part: register 107

Address: -108 -109 -110 -111
-112 -113 -114 -115

Conversion average Alx

Default

-

Description

Converted analogue signal average

Values' range

0 - 4294967295

AI1

Low part: register 108

High part: register 109

AI2

Low part: register 110

High part: register 111

AI3

Low part: register 112

High part: register 113

AI4

Low part: register 114

High part: register 115

Address: -150 -151 -152 -153
-154 -155 -156 -157

Encoder counter x (BIS)

Default

-

Values' range

0 - 4294967295

Description

Copy of the **Encoder counter x** registers but with the word order reversed

Encoder 1

Low part: register 151

High part: register 150

Encoder 2

Low part: register 153

High part: register 152

Encoder 3

Low part: register 155

High part: register 154

Encoder 4

Low part: register 157

High part: register 156

Address: -158 -159 -160 -161
-162 -163 -164 -165

Encoder counter (1 s) x (BIS)

Default

-

Values' range

0 - 4294967295

Description

Copy of registers **Encoder counter (1 s) x** but with the order of words reversed

Encoder 1

Low part: register 159

High part: register 158

Encoder 2

Low part: register 161

High part: register 160

Encoder 3

Low part: register 163

High part: register 162

Encoder 4

Low part: register 165

High part: register 164

Address: -166 -167 -168 -169
-170 -171 -172 -173

Encoder counter (100 ms) x (BIS)

Default

-

Values' range

0 - 4294967295

Description

Copy of registers **Encoder counter (100 ms) x** but with the order of words reversed

Encoder 1

Low part: register 167

High part: register 166

Encoder 2

Low part: register 169

High part: register 168

Encoder 3

Low part: register 171

High part: register 170

Encoder 4

Low part: register 173

High part: register 172

Address: -501	Active connection
Default -	Description Number of active connections on the device
Values' range 0 - 65535	
Address: -502	Valid answers
Default -	Description Number of valid responses sent to the Modbus TCP/IP client or valid responses received via the serial interface
Values' range 0 - 65535	
Address: -503	CRC errors counter
Default -	Description Number of responses received with CRC errors on the serial interface
Values' range 0 - 65535	
Address: -504	Exception errors counter
Default -	Description Number of exceptions sent to the Modbus TCP/IP client or responses received via the serial interface containing exceptions
Values' range 0 - 65535	
Address: -505	TCP/IP errors counter
Default -	Description Number of errors or disconnections detected during the TCP/IP connection
Values' range 0 - 65535	
Address: -506	TCP/IP timeout errors counter
Default -	Description Number of connections closed when the set timeout expires; see parameters: Enable idle timeout and Server Idle timeout
Values' range 0 - 65535	

7.3 Coils

Address:

-0	Digital Output Q 0.0
-1	Digital Output Q 0.1
-2	Digital Output Q 0.2
-3	Digital Output Q 0.3
-4	Digital Output Q 0.4
-5	Digital Output Q 0.5
-6	Digital Output Q 0.6
-7	Digital Output Q 0.7
-8	Digital Output I/Q 1.0
-9	Digital Output I/Q 1.1
-10	Digital Output I/Q 1.2
-11	Digital Output I/Q 1.3
-12	Digital Output I/Q 1.4
-13	Digital Output I/Q 1.5
-14	Digital Output I/Q 1.6
-15	Digital Output I/Q 1.7

Information Upon restarting, the outputs are always reset to zero.

7.4 Discrete Inputs

Address:

-0	Digital Input I 0.0
-1	Digital Input I 0.1
-2	Digital Input I 0.2
-3	Digital Input I 0.3
-4	Digital Input I 0.4
-5	Digital Input I 0.5
-6	Digital Input I 0.6
-7	Digital Input I 0.7
-8	Digital Input I/Q 1.0
-9	Digital Input I/Q 1.1
-10	Digital Input I/Q 1.2
-11	Digital Input I/Q 1.3
-12	Digital Input I/Q 1.4
-13	Digital Input I/Q 1.5
-14	Digital Input I/Q 1.6
-15	Digital Input I/Q 1.7

8 Configuration parameters and registers

8.1 Holding registers

Address: -501	RTU Baudrate
Default 8 (115200)	Description Defines the communication speed of the RS485 port
Values' range 1 - 8	1: 2400bps 2: 4800bps 3: 9600bps 4: 19200bps 5: 28800bps 6: 38400bps 7: 57600bps 8: 115200bps
Address: -502	RTU Frame format
Default 1 (data: 8 bits stop: 1 bit parity: none)	Description Defines the data format used on the RS485 port
Values' range 1 - 6	1: data: 8 bits stop: 1 bit parity: none 2: data: 8 bits stop: 1 bit parity: even 3: data: 8 bits stop: 1 bit parity: odd 4: data: 8 bits stop: 2 bits parity: none 5: data: 8 bits stop: 2 bits parity: even 6: data: 8 bits stop: 2 bits parity: odd
Address: -503	RTU Time out
Default 100	Description Defines the maximum waiting time for a response from the Modbus RTU module in milliseconds.
Values' range [ms] 10 - 10000	
Address: -504	ID Modbus
Default 247	Description Defines the Modbus ID of the module
Values' range 1 - 247	
Address: -505	DHCP enable
Default 1	Description Enabling DHCP mode
Values' range 1 - 2	1: NO 2: YES

Address: -506	Modbus Port
Default 502	Description Defines the Ethernet communication port
Values' range 1 - 12000	
Address: -507	Bridge Mode
Default 1	Description Enabling Bridge mode
Values' range 1 - 2	1: NO 2: YES
Address: -510 -511 -512 -513	IP address
Default 192.168.0.175	Description Set the IP address of the module
	First part: register 510 Second part: register 511 Third part: register 512 Fourth part: register 513
Address: -514 -515 -516 -517	Subnet mask
Default 255.255.0.0	Description Set the module's subnet mask
	First part: register 514 Second part: register 515 Third part: register 516 Fourth part: register 517
Address: -518 -519 -520 -521	Gateway
Default 0.0.0.0	Description Set the module gateway
	First part: register 518 Second part: register 519 Third part: register 520 Fourth part: register 521
Address: -522 -523 -524 -525	DNS
Default 0.0.0.0	Description Set the module's DNS
	First part: register 522 Second part: register 523 Third part: register 524 Fourth part: register 525

Address: -526

Enable idle timeout

Default

1

Values' range

1 - 2

Description

Enable automatic disconnection of the TCP/IP client if no incoming network traffic is detected for a specified period of time

- 1: NO
- 2: YES

Address: -527

Server idle timeout

Default

600

Values' range

1 - 7200

Description

The idle timeout period, expressed in seconds, after which the server automatically disconnects the TCP/IP client.

This parameter is only active when the **Enable Idle Timeout option** is enabled.

Address: -528

Time between messages

Default

0

Values' range

1 - 10000

Description

An additional time interval inserted between the transmission of one message and the sending of the next. This parameter allows you to adjust the timing of communications, thereby reducing the load on the line.

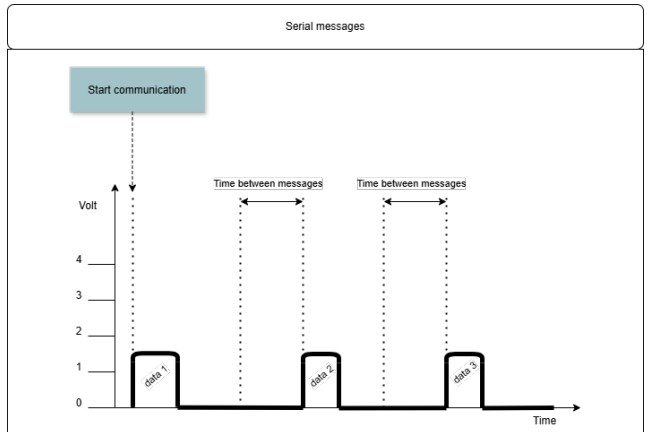

Address: -530 -531 -532 -534
-535 -536 -537 -538
-539 -540 -541

Device name

Default
mcm280x

Description
Set the name of the module visible on MyPixsys Lab

Digits 1-2: register 530
Digits 3-4: register 531
Digits 5-6: register 532
Digits 7-8: register 533
Digits 9-10: register 534
Digits 11-12: register 535
Digits 13-14: register 536
Digits 15-16: register 537
Digits 17-18: register 538
Digits 19-20: register 539
Digits 21-22: register 540
Digits 23-24: register 541

Address: -542

Offline timeout

Default
0

Description
The period of inactivity, expressed in seconds, after which the device activates the digital outputs in accordance with the configuration set by the **Offline outputs bitmask**, **Offline AO1** and **Offline AO2** parameters

Values' range
0.00 - 600.00

Address: -543

Offline outputs bitmask

Default
0

Description
A bit mask that defines the state of the digital outputs when the system is switched to offline mode

Values' range
1 - 65535

Address: -544

Enable offline

Default
1

Description
Enabling offline mode

Values' range
1 - 2

1: NO
2: YES

Address: -545

Offline AO1

Default
0

Description
Value of analogue output AO1 when the system goes offline

Values' range
-32768 - 32767

Address: -546

Offline AO2

Default
0

Description
Value of analogue output AO2 when the system goes offline

Range di valori
-32768 - 32767

Address: -550 -551 -522 -553

Sensor type AIx

Default

0

Description

Configuring the analogue input based on the sensor type:

Values' range

0 - 23

Sensor type AI1: register 550

Sensor type AI2: register 551

Sensor type AI3: register 552

Sensor type AI4: register 553

0:	Disable	
1:	Tc K	-260 °C..1360 °C
2:	Tc S	-40 °C..1760 °C
3:	Tc R	-40 °C..1760 °C
4:	Tc J	-200 °C..1200 °C
5:	Tc T	-260 °C..400 °C
6:	Tc E	-260 °C..980 °C
7:	Tc N	-260 °C..1280 °C
8:	Tc B	100 °C..1820 °C
9:	PT100	-100 °C..600 °C
10:	NI100	-60 °C..180 °C
11:	NTC-10K	-40 °C..125 °C
12:	PTC-1K	-50 °C..150 °C
13:	PT500	-100 °C..600 °C
14:	PT1000	-100 °C..600 °C
15:	0..1 V	
16:	0..5 V	
17:	0..10 V	
18:	0.200 mA	
19:	4..20 mA	
20:	0..60 mA	
21:	Potentiometer	(see Potentiometer value AIx)
22:	Count PGA 64	
23:	Count PGA 128	

Address: -554

Temperature measurement unit

Default

0

Description

Set the temperature measurement unit

Values' range

0 - 2

0:	Celsius
1:	Fahrenheit
2:	Kelvin

Address: -555 -556 -557 -558

Lower limit AIx

Default

0

Description

Lower limit of analogue input AIx (applicable only to standardised signals).

Values' range [digit]

-32768 - +32767

In the case of a 4–20mA input, the value is associated with 4mA.

Address: -559 -560 -561 -562

Upper limit Alx

Default

1000

Values' range [digit]

-32768 - +32767

Description

Upper limit of analogue input **Alx** (applicable only to standardised signals).

In the case of a 4–20mA input, the value is associated with 20mA.

Address: -563 -564 -565 -566

Potentiometer value Alx

Default

10

Values' range [kΩ]

1 - 150

Description

Value of the potentiometer connected to the **Alx** input if the corresponding **Sensor type Alx** parameter is set to **Potentiometer**.

Address: -567 -568 -569 -570

Linear overrange limit Alx

Default

0

Values' range

0 - 1

Description

Enables the **Alx** analogue input overrange in linear mode, allowing the process to exceed the nominal limits set on **Lower limit Alx** and **Upper limit Alx**.

0: OFF

1: ON

Address: -571 -572 -573 -574

Offset calibration Alx

Default

0

Values' range

-10000 - +10000

Description

Value that is subtracted or added to the corresponding value of **Alx**

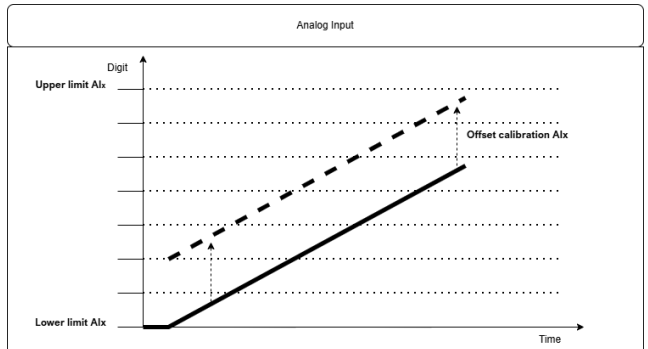

Address: -575 -576 -577 -578

Gain calibration Alx

Default

0

Description

Value that is multiplied by the corresponding value of Alx

Values' range [%]

-1000 (-100%) - +1000 (+100%)

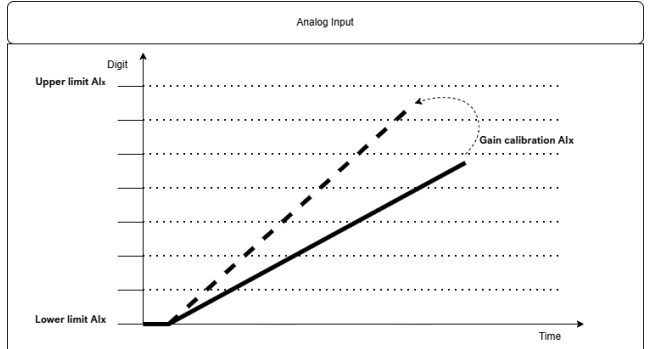

Address: -579 -580 -581 -582

Filter Alx

Default

10

Description

Stabilises the analogue input value by defining the number of samples used for the process average.

Values' range

1 - 50

Address: -583 -584 -585 -586

Maximum Acceptable Delta Alx

Default

10.0

Description

Defines the maximum absolute value allowed between the current process value and the new sampling for the latter to be considered valid. If the delta falls within the limit, the sampling is included in the average managed by the **Filter Alx** parameter; otherwise, it is discarded.

Values' range [digit] o [0.1 °C]

1 - 32767

Address: -587 -588 -589 -590

Maximum Rejection Time Alx

Default

1.0

Description

Defines the maximum time during which analogue input samples can be discarded if deemed unacceptable (see **Maximum Acceptable Delta Alx**)
At the end of this interval, any new samples are considered valid and accepted by the process..

Values' range [0.1s]

1 - 200

Address: -591 -592

Sampling Frequency Alx Aly

Default

5

Values' range

0-13

Description

Sampling frequency of the analogue-to-digital converter. Lower frequencies stabilise the reading, but slow down data updates.

Higher frequencies increase the sampling speed at the expense of the stability of the acquired value.

Sampling Frequency AI1 AI2: register 591

Sampling Frequency AI3 AI4: register 592

0:	4 Hz
1:	6 Hz
2:	8 Hz
3:	10 Hz
4:	12 Hz
5:	17 Hz
6:	20 Hz
7:	33 Hz
8:	39 Hz
9:	50 Hz
10:	62 Hz
11:	123 Hz
12:	242 Hz
13:	470 Hz

Address: -593

Digital input filter

Default

5

Values' range [ms]

0 - 250

Description

Minimum stability duration of the digital input required for signal validation.

Address: -594 -595 -596 -597

Encoder/Counter type x

Default

0

Values' range

0 - 6

Description

Set the operating mode of the encoder or counter input.

0:	Disable
1:	Encoder x2 phase A-B
2:	Encoder x4 phase A-B
3:	Encoder x2 phase A-B-Z
4:	Encoder x4 phase A-B-Z
5:	Counter Up
6:	Counter Down (Not available for Encoder 4)

Address: -598 -599 -600 -601
-602 -603 -604 -605

Encoder preset x

Default

0

Values' range [digit]

-2147483648 - 2147483647

Description

Value that is loaded into the encoder x counter registers when the relevant command is sent.

The value is 32 bits and is divided into two 16-bit registers.

Encoder 1

Low part: register 598

High part: register 599

Encoder 2

Low part: register 600

High part: register 601

Encoder 3

Low part: register 602

High part: register 603

Encoder 4

Low part: register 604

High part: register 605

Address: -606 -607

AOx mode

Default

0

Description

Select the operating mode of analogue output AOx

Values' range

0 - 1

0 = 0 - 10 Volt

1 = 4 - 20 mA

Address: -608 -609

Lower limit AOx

Default

0

Description

Lower limit of AOx output

The value is associated with 0V or 4mA depending on the configuration

Values' range [digit]

-32768 - +32767

Address: -610 -611

Upper limit AOx

Default

1000

Description

Upper limit of AOx output

The value is associated with 10V or 20mA depending on the configuration

Values' range [digit]

-32768 - +32767

Address: -612 -613

Error value AOx

Default

0

Description

Value of analogue output AOx in the event of an error or fault

Values' range [digit]

Lower limit AO1- Upper limit AO1

0

Lower limit AO2- Upper limit AO2

Default

0

Description

Select the operating mode of the PTOx output.

Values' range

0 - 2

0 = ON/OFF

2 = PWM

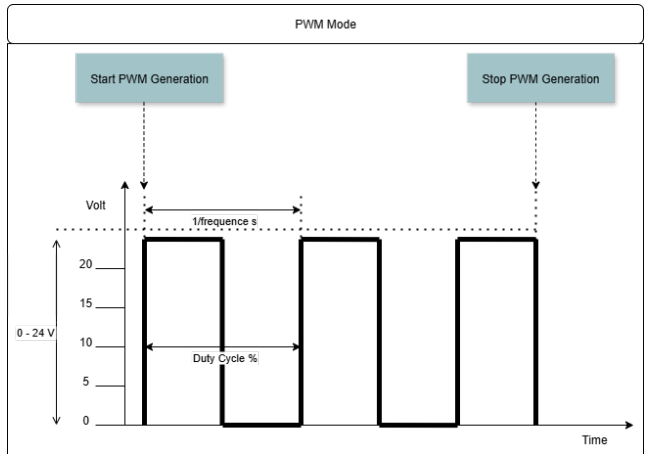
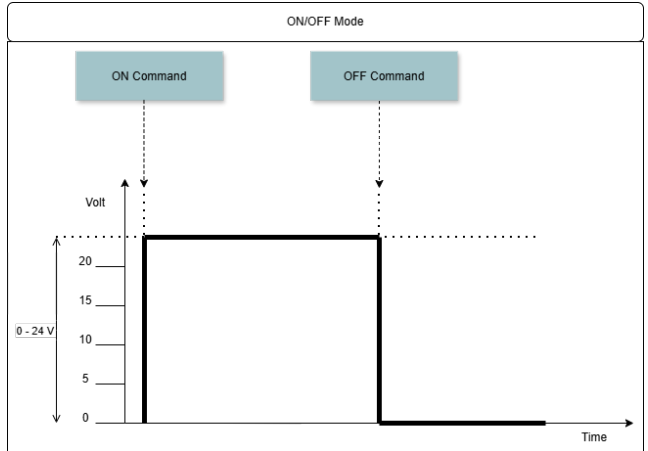

Address: -700 -701 -702 -703
-704 -705 -706 -707

Encoder preset x (BIS)

Default

0

Values' range [digit]

-2147483648 - 2147483647

Description

Copy of the **Encoder preset x** registers but with the word order reversed.

Encoder 1

Low part: register 701

High part: register 700

Encoder 2

Low part: register 703

High part: register 702

Encoder 3

Low part: register 705

High part: register 704

Encoder 4

Low part: register 707

High part: register 706

9 Configuring the device with MyPixsys Lab

9.1 Connection with the MCM280 module

- 1 If you have not already done so, install the MyPixsys Lab desktop application by downloading the installation file from the website page:

<https://www.pixsys.net/en/software-and-solutions/mypixsyslab>

see SOFTWARE section.

- 2 Start the application



- 3 Connect the MCM280X to the PC network and switch on the device. The MCM280X has a default IP address of **192.168.0.175**, but it is not necessary to change the IP address on the PC network card to connect. If the connection has been made correctly, the pop-up message **Remote device available** will appear.



- 4 Select the network card you wish to use:

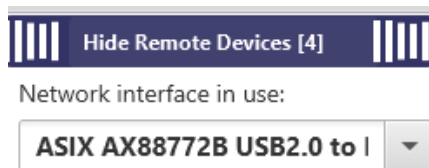

- 5 Opening the pop-up window displays the devices present in the network to which the PC is connected.



- 6 Press the **Connect** button to open the configuration menu for the selected module.



- 7 All parameters for the selected instrument are displayed, divided into groups. Pressing the **READ** button reads and compiles all data and configurations from the tables in the module.

MCM280X
mcm280x

automatic connection
Connected!
- click to disconnect -

READ

WRITE

Display Remote Devices (5)

Ethernet Interface

RTU Interface	ID	Acronym	Name	Value
Ethernet Interface	P_4		Slave ID	247
Analog Input 1	P_5		DHCP	NO
Analog Input 2	P_6		Modbus Port	502
Analog Input 3	P_10		IP Address	192 : 168 : 2 : 24
Analog Input 4	P_14		Subnet Address	255 : 255 : 0 : 0
Analog configuration	P_18		Gateway Address	0 : 0 : 0 : 0
Digital Input	P_22		DNS Address	0 : 0 : 0 : 0
Encoder Input	P_30		Device Name	mcm280x
Analog Output 1				
Analog Output 2				
PTO Output				

Utilities

9.2 Parameters configuration

- 1 Configure the device by selecting values from the drop-down menus or editing the alphanumeric fields.

An arrow will appear next to all parameters that are modified ↻

If you wish to reset the parameters to their initial values, press the arrow key ↻

Frame format: 8,n,1

Slave response waiting time: 508 ms

- 2 After setting all parameters, press the **WRITE** button.



Information!

To make changes to parameters or tables effective, it is always necessary to restart the device.

9.3 Saving the device configuration

- 1 Once you have configured the module, open the **File** menu and select **Save configuration**.

MCM280X

File Settings Help

MCM280X automatic connection

- 2 Select the directory where you want to save the MCM280X.atr file and press **Save**.

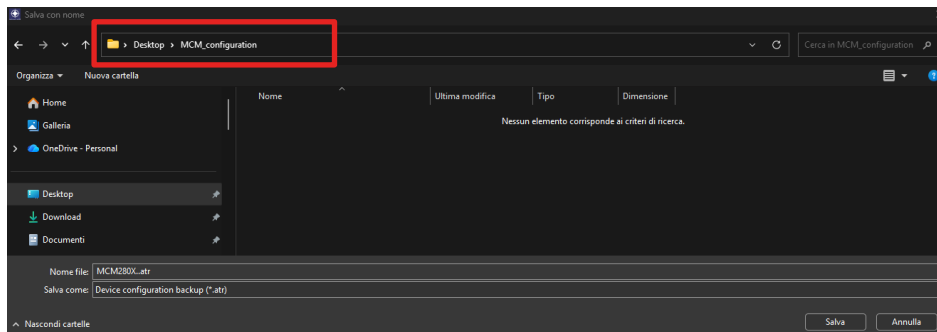

- 3 The generated file can be used to load the same configuration onto a new device.

9.4 Loading device configuration from Backup file

- 1 Open the **.atr** file from the File menu and select **Import configuration**.

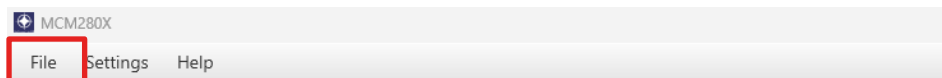

- 2 Connettersi al modulo da configurare



- 3 Press the button **WRITE all**



Introduzione

Grazie per aver scelto uno strumento Pixsys.

Il modulo MCM280X è un dispositivo che mette a disposizione tramite il protocollo Modbus TCP/IP le sue risorse Hardware.

La configurazione può avvenire attraverso gli opportuni Registri Modbus TCP/IP oppure tramite l'applicazione MyPixsys Lab.

1 Norme di sicurezza

Prima di utilizzare il dispositivo leggere con attenzione le istruzioni e le misure di sicurezza contenute in questo manuale. Disconnettere l'alimentazione prima di qualsiasi intervento su connessioni elettriche o settaggi hardware al fine di prevenire il rischio di scosse elettriche, incendio o malfunzionamenti.

Non installare e non mettere in funzione lo strumento in ambienti con sostanze infiammabili, gas o esplosivi. Questo strumento è stato progettato e realizzato per l'utilizzo convenzionale in ambienti industriali e per applicazioni che prevedano condizioni di sicurezza in accordo con la normativa nazionale e internazionale sulla tutela della delle persone e la sicurezza dei luoghi di lavoro. Deve essere evitata qualsiasi applicazione che comporti gravi rischi per l'incolumità delle persone o sia correlata a dispositivi medici salvavita. Lo strumento non è progettato e realizzato per installazione in centrali nucleari, armamenti, sistemi di controllo del traffico aereo o della sicurezza in volo, sistemi di trasporto di massa. L'utilizzo/manutenzione è riservato a personale qualificato ed è da intendersi unicamente nel rispetto delle specifiche tecniche dichiarate in questo manuale.

Non smontare, modificare o riparare il prodotto né toccare nessuna delle parti interne.

Lo strumento va installato e utilizzato esclusivamente nei limiti delle condizioni ambientali dichiarate.

Un eventuale surriscaldamento può comportare rischi di incendio e abbreviare il ciclo di vita dei componenti elettronici.

1.1 Organizzazione delle note di sicurezza

Le note sulla sicurezza in questo manuale sono organizzate come segue:

Note di sicurezza	Descrizione
Danger!	La mancata osservanza di queste linee guida e avvisi di sicurezza può essere potenzialmente mortale.
Warning!	La mancata osservanza di queste linee guida e avvisi di sicurezza può comportare lesioni gravi o danni sostanziali alla proprietà.
Information!	Tali informazioni sono importanti per prevenire errori.

1.2 Note di sicurezza

Danger!	ATTENZIONE - Rischio di incendio e scosse elettriche. Questo prodotto è classificato come apparecchiatura di controllo del processo di tipo a barra DIN. Deve essere montato in un involucro che non permetta al fuoco di fuoriuscire esternamente.
Warning!	I dispositivi devono essere alimentati a energia limitata secondo UL 61010-1 3rd Ed, sezione 9.4 o LPS in conformità con UL 60950-1 o SELV in conformità con UL 60950-1 o Classe 2 in conformità con UL 1310 o UL 1585.
Warning!	Occasionalmente le viti troppo allentate possono provocare un incendio. Per i morsetti a vite, serrare le viti alla coppia di serraggio di 0.5 Nm (morsetti passo a 5 mm) o 0.25 Nm (morsetti passo a 3.81 mm)
Warning!	Un malfunzionamento nel dispositivo può occasionalmente rendere impossibili le operazioni di controllo o bloccare le uscite di allarme, con conseguenti danni materiali. Per mantenere la sicurezza, in caso di malfunzionamento, adottare misure di sicurezza appropriate; ad esempio con l'installazione di un dispositivo di monitoraggio indipendente e su una linea separata.

1.3 Precauzioni per l'uso sicuro

Assicurarsi di osservare le seguenti precauzioni per evitare errori, malfunzionamenti o effetti negativi sulle prestazioni e le funzioni del prodotto. In caso contrario, occasionalmente potrebbero verificarsi eventi imprevedibili. Non utilizzare il controller digitale oltre i valori nominali.

- Il prodotto è progettato solo per uso interno. Non utilizzare o conservare il prodotto all'aperto o in nessuno dei seguenti posti:
 - Luoghi direttamente soggetti a calore irradiato da apparecchiature di riscaldamento.
 - Luoghi soggetti a spruzzi di liquido o atmosfera di petrolio.
 - Luoghi soggetti alla luce solare diretta.
 - Luoghi soggetti a polvere o gas corrosivi (in particolare gas di solfuro e gas di ammoniaca).
 - Luoghi soggetti a forti sbalzi di temperatura.
 - Luoghi soggetti a formazione di ghiaccio e condensa.
 - Luoghi soggetti a vibrazioni e forti urti.
- L'utilizzo di due o più controller affiancati o uno sopra l'altro possono causare un incremento di calore interno che ne riduce il ciclo di vita. In questo caso si raccomanda l'uso di ventole per il raffreddamento forzato o altri dispositivi di condizionamento della temperatura interno quadro.
- Controllare sempre i nomi dei terminali e la polarità e assicurarsi di effettuare una cablatrice corretta. Non collegare i terminali non utilizzati.
- Per evitare disturbi induttivi, mantenere il cablaggio dello strumento lontano da cavi di potenza con tensioni o correnti elevate. Inoltre, non collegare linee di potenza insieme o in parallelo al cablaggio dello strumento. Si consiglia l'uso di cavi schermati e condotti separati. Collegare un limitatore di sovratensione o un filtro antirumore ai dispositivi che generano rumore (in particolare motori, trasformatori, solenoidi, bobine o altre apparecchiature con componenti induttivi). Quando si utilizzano filtri antidisturbo sull'alimentazione, controllare tensione e corrente e collegare il filtro il più vicino possibile allo strumento. Lasciare più spazio possibile tra il controller e dispositivi di potenza che generano alte frequenze (saldatrici ad alta frequenza, macchine per cucire ad alta frequenza, ecc.) o sovratensioni.
- Un interruttore o un sezionatore deve essere posizionato vicino al regolatore. L'interruttore o il sezionatore deve essere facilmente raggiungibile dall'operatore e deve essere contrassegnato come mezzo di disconnessione per il controller.
- Rimuovere lo sporco dallo strumento con un panno morbido e asciutto. Non usare mai diluenti, benzina, alcool o detersivi che contengano questi o altri solventi organici. Possono verificarsi deformazioni o scolorimento.
- Il numero di operazioni di scrittura della memoria non volatile è limitato. Tenere conto di questo quando si utilizza la modalità di scrittura in EEPROM ad esempio nella variazione dei dati durante le comunicazioni seriali.

1.4 Tutela ambientale e smaltimento dei rifiuti / Direttiva WEEE

Non smaltire le apparecchiature elettriche ed elettroniche tra i rifiuti domestici. Secondo la Direttiva Europea 2012/19/EU le apparecchiature esauste devono essere raccolte separatamente al fine di essere reimpiegate o riciclate in modo eco-compatibile.

2 Identificazione del modello

MCM280X-20AD	EXP/PLC 9 MODULES 161X90 - MODBUS TCP 8DI,8DO,8DI/O,4AI,2AO,2PTO,ETH,RS485
--------------	---

3 Dimensioni e installazione

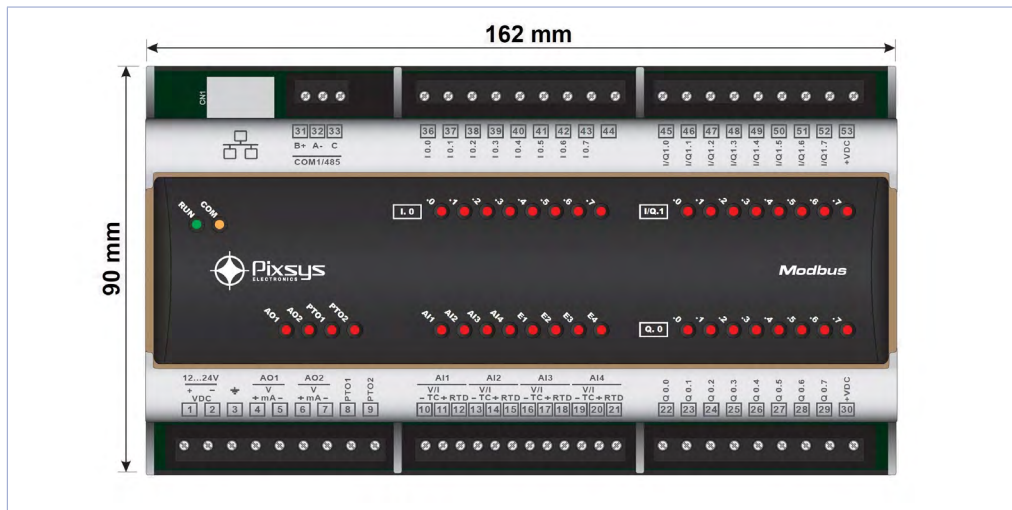

4 Dati tecnici

4.1 Caratteristiche generali

Alimentazione	12..24 VDC \pm 10% Class2
Consumo	100W
Condizioni operative	Temperatura: 0-45 °C -Umidità 35..95 uR% Max. altitudine: 2000m
Protezione	IP20 (contenitore e morsettiere)
Materiali	Frontale: Gomma siliconica V0 autoestinguente
Peso	Circa 380 g

4.2 Caratteristiche Hardware

Ingressi digitali	8 ingressi PNP 12-24Vdc (sovrapposti alle uscite digitali)	$V_{IL} = 4,4V$ $V_{IH} = 8,2V$
Uscite digitali	8 uscite statiche 12-24Vdc	Max 700mA per uscita Max 2A in totale (Q.0.0-Q.0.7)
Canali digitali multifunzione	8 PNP 12-24 Vdc oppure PNP statico 12-24 Vdc	Ingressi: $V_{IL} = 4,4V$ $V_{IH} = 8,2V$ Uscite: Max 700mA per uscita Max 2A in totale (Q.1.0-Q.1.7)
Ingressi encoder/ contatore	4 encoder/contatori sovrapposti agli ingressi digitali PNP	Risoluzione 32 bit Frequenza massima 100KHz
Ingressi analogici	4 ingressi configurabili via software Termocoppie: tipo K, S, R, J, T, E, N, B; compensazione automatica del giunto freddo da 0..50°C. Termoresistenze: PT100, PT500, PT1000, Ni100, PTC1K, NTC10K (β 3435K) Ingresso V/I: 0-10V, 0-1V, 0-5V, 0-20mA, 4-20mA, 0-60mV. Potenziometri: 1..150K Ω	Galvanicamente isolati da alimentazio- ne e porta di comunicazione Risoluzione 16 bit Tolleranza (25 °C) +/-0.2% \pm 1 digit (su F.s.)
Uscite analogiche	2 uscite configurabili via software: 0-10V o 4-20mA	Risoluzione 16 bit
Uscite PTO	2 uscite configurabili: ON/OFF, PWM, 12-24Vdc	Max: 20mA Max freq.: 200kHz
Porta seriale COM1	1 \times RS485 con protocollo Modbus RTU, con funzione di gateway/bridge Modbus TCP-RTU trasparente, capacit� massima 32 nodi.	
Porta Ethernet	1 porta RJ45 Fast Ethernet 10/100 Mbit.	Per la configurazione dei parametri tramite software per PC MyPixsys Lab e programmazione da ambiente di sviluppo LogicLab, protocollo Modbus TCP/IP slave.

4.3 Collegamenti elettrici

Caution! Questo dispositivo   stato progettato e costruito in conformit  alle Direttive Compatibilit  elettromagnetica 2004/108/CE e 2014/30/UE (EMC).

Per l'installazione in ambienti industriali   buona norma seguire le seguenti precauzioni:

- Distinguere la linea di alimentazioni da quelle di potenza.
- Evitare la vicinanza di gruppi di teleruttori, contattori elettromagnetici, motori di grossa potenza e comunque usare appositi filtri.
- Evitare la vicinanza di gruppi di potenza, in particolare se a controllo di fase.
- Si raccomanda l'impiego di filtri di rete sull'alimentazione della macchina in cui lo strumento verr  installato, in particolare nel caso di alimentazione 230 VAC. Si evidenzia che lo strumento   concepito per essere assemblato ad altre macchine e dunque la marcatura CE dello strumento non esime il costruttore dell'impianto dagli obblighi di sicurezza e conformit  previsti per la macchina nel suo complesso.
- Per cablare i morsetti utilizzare puntalini a tubetto crimpati o filo di rame flessibile o rigido di sezione compresa tra 0.15 e 1.5 mm² (min. AWG28, max. AWG16, temperatura operativa: min. 70°C). La lunghezza di spelatura   compresa tra 7 e 8 mm.

4.3.a Alimentazione

	<p>Alimentazione 12..24Vdc ±10%</p> <ul style="list-style-type: none"> 1: +Vdc 2: -Vdc
---	--

4.3.b Ingressi digitali

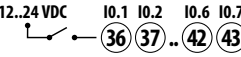
	<p>36: Ingresso I0.0 37: Ingresso I0.1 38: Ingresso I0.2 39: Ingresso I0.3 40: Ingresso I0.4 41: Ingresso I0.5 42: Ingresso I0.6 43: Ingresso I0.7</p>
--	---

4.3.c Uscite digitali

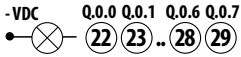
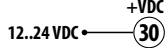
	<p>22: Uscita Q0.0 23: Uscita Q0.1 24: Uscita Q0.2 25: Uscita Q0.3 26: Uscita Q0.4 27: Uscita Q0.5 28: Uscita Q0.6 29: Uscita Q0.7</p>
	<p>Alimentazione uscite digitali Q0.0 -Q0.7</p>

4.3.d Canali digitali multifunzione

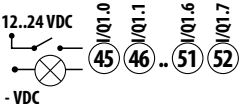
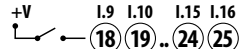
	<p>45: Ingresso/Uscita I/Q1.0 46: Ingresso/Uscita I/Q1.1 47: Ingresso/Uscita I/Q1.2 48: Ingresso/Uscita I/Q1.3 49: Ingresso/Uscita I/Q1.4 50: Ingresso/Uscita I/Q1.5 51: Ingresso/Uscita I/Q1.6 52: Ingresso/Uscita I/Q1.7</p>
	<p>Alimentazione uscite digitali Q1.0 -Q1.7</p>

4.3.e Ingressi encoder/encoder

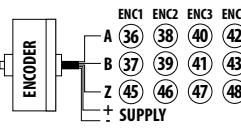
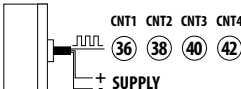
	<p>Encoder Push-Pull Usare solo encoder di tipo push-pull Frequenza massima 100kHz</p>
	<p>Counter Ingressi PNP Frequenza massima 100kHz</p>

4.3.f Ingressi analogici

	<p>Segnali in tensione 0..10V, 0..1V, 0..5V, 0..60mV Segnali in corrente 0..20 mA, 4..20mA</p>
--	---

4.3.g Termocoppie

	<p>Ingressi analogici per termocoppie K, S, R, J, T, E, N, B.</p> <ul style="list-style-type: none"> • Rispettare la polarità • Per eventuali prolunghe utilizzare cavo compensato e morsetti adatti alla termocoppia utilizzata (compensati)
--	--

4.3.h Termoresistenze

	<p>Per il collegamento a tre fili usare cavi della stessa sezione. Per il collegamento a due fili cortocircuitare i morsetti 11 e 12 (AI1), 14 e 15 (AI2), 17 e 18 (AI3), 20 e 21 (AI4).</p>
--	---

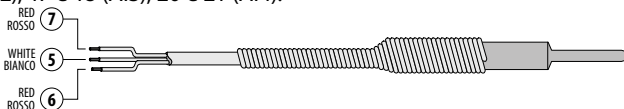

	<p>Ingressi analogici per termoresistenze NTC-10K, PTC-1K, PT500, PT1000 e potenziometri lineari.</p>
--	--

4.3.i Uscite analogiche

	<p>Configurabile: 0-10 V con 30000 punti $\pm 0.3\%$ (su F.S.) 25 °C; carico $\geq 1 \text{ K}\Omega$ 4-20 mA con 25000 punti $\pm 0.3\%$ (su F.S.) 25 °C; carico $\leq 500\Omega$</p>
--	--

4.3.j Uscite PTO

	<p>Configurabile: ON/OFF: attivazione in modalità on ON/OFF come uscita digitale PWM: Uscita PWM con frequenza e duty cycle variabile Collegare le uscite PTO con riferimento a 0V del morsetto 2</p>
--	--

4.3.k Porta seriale COM1

	<p>31: (B+) RS485+ 32: (A-) RS485- 33: (C) Riferimento Collegare l'eventuale schermo del cavo al morsetto 3</p>
--	--

4.3.1 Porta Ethernet



Tipo di connettore: RJ45 (femmina). Porta Ethernet 10/100 Mbit per la configurazione dei parametri e la connettività di rete

5 Specifiche di funzionamento

5.1 Descrizione generale

Il modulo **MCM280X** è un I/O remoto **Modbus TCP/IP** dotato della funzionalità **Bridge**, che consente di comunicare con altri dispositivi collegati alla porta seriale tramite **Modbus RTU**. La memoria Modbus è strutturata per semplificare la configurazione e l'utilizzo del modulo; alcuni registri sono duplicati per aumentarne la versatilità e la flessibilità operativa.

5.2 Configurazione dei parametri

Al primo avvio il dispositivo è sempre configurato con i parametri di default, ogni volta che verranno impostati nuovi parametri di configurazione sarà necessario spegnere e riaccendere, o riavviare il dispositivo.

Ad ogni avvio i parametri salvati vengo letti, ed il dispositivo configura la comunicazione Modbus con l'ultima configurazione impostata.

I parametri posso essere settati mediante:

- scrittura dei relativi registri Modbus TCP/IP (default 192.168.0.175, slave ID 247)
- scrittura con applicazione Desktop Mypixsys Lab

5.3 Mappatura dei registri Modbus

Lista registri predefiniti per l'accesso e l'utilizzo delle risorse hardware integrate.

Holding register	Name	Access
0	En/Status PTO Outputs	R/W
1	Value AO1	R/W
2	Value AO2	R/W
3	Commands Encoder 1	R/W
4	Commands Encoder 2	R/W
5	Commands Encoder 3	R/W
6	Commands Encoder 4	R/W
11	Frequency PWM PTO1 L	R/W
12	Frequency PWM PTO1 H	R/W
13	Frequency PWM PTO2 L	R/W
14	Frequency PWM PTO2 H	R/W
15	Duty Cycle PTO1	R/W
16	Duty Cycle PTO2	R/W
17	Commands PTO1	R/W
18	Commands PTO2	R/W
19	Digital Output bit mask	R/W
54	Frequency PWM PTO1 H (BIS)	R/W
55	Frequency PWM PTO1 L (BIS)	R/W
56	Frequency PWM PTO2 H (BIS)	R/W
57	Frequency PWM PTO2 L (BIS)	R/W
100	Offline Counter	R/W
501	RTU Baudrate	R/W

Holding register	Name	Access
502	RTU frame format	R/W
503	RTU time-out	R/W
504	RTU slave id	R/W
505	DHCP enable	R/W
506	Modbus port	R/W
507	Bridge enable	R/W
510	IP address part 1	R/W
511	IP address part 2	R/W
512	IP address part 3	R/W
513	IP address part 4	R/W
514	Subnet mask part 1	R/W
515	Subnet mask part 2	R/W
516	Subnet mask part 3	R/W
517	Subnet mask part 4	R/W
518	Gateway part 1	R/W
519	Gateway part 2	R/W
520	Gateway part 3	R/W
521	Gateway part 4	R/W
522	Dns part 1	R/W
523	Dns part 2	R/W
524	Dns part 3	R/W
525	Dns part 4	R/W
526	Enable idle timeout	R/W
527	TCP/IP server timeout	R/W
528	Time between messages	R/W
530	Device name characters 1 - 2	R/W
531	Device name characters 3 - 4	R/W
532	Device name characters 5 - 6	R/W
533	Device name characters 7 - 8	R/W
534	Device name characters 9 - 10	R/W
535	Device name characters 11 - 12	R/W
536	Device name characters 13 - 14	R/W
537	Device name characters 15 - 16	R/W
538	Device name characters 17 - 18	R/W
539	Device name characters 19 - 20	R/W
540	Device name characters 21 - 22	R/W
541	Device name characters 23 - 24	R/W
542	Offline timeout	R/W
543	Offline outputs bitmask	R/W
544	Enable offline	R/W
545	Offline AO1 value	R/W
546	Offline AO2 value	R/W
550	Sensor type AI1	R/W
551	Sensor type AI2	R/W
552	Sensor type AI3	R/W
553	Sensor type AI4	R/W
554	Temperature Unit Setting	R/W

Holding register	Name	Access
555	Lower limit AI1	R/W
556	Lower limit AI2	R/W
557	Lower limit AI3	R/W
558	Lower limit AI4	R/W
559	Upper limit AI1	R/W
560	Upper limit AI2	R/W
561	Upper limit AI3	R/W
562	Upper limit AI4	R/W
563	Potentiometer value AI1	R/W
564	Potentiometer value AI2	R/W
565	Potentiometer value AI3	R/W
566	Potentiometer value AI4	R/W
567	Linear overrange limit AI1	R/W
568	Linear overrange limit AI2	R/W
569	Linear overrange limit AI3	R/W
570	Linear overrange limit AI4	R/W
571	Offset calibration AI1	R/W
572	Offset calibration AI2	R/W
573	Offset calibration AI3	R/W
574	Offset calibration AI4	R/W
575	Gain calibration AI1	R/W
576	Gain calibration AI2	R/W
577	Gain calibration AI3	R/W
578	Gain calibration AI4	R/W
579	Filter AI1	R/W
580	Filter AI2	R/W
581	Filter AI3	R/W
582	Filter AI4	R/W
583	Maximum Acceptable Delta AI1	R/W
584	Maximum Acceptable Delta AI2	R/W
585	Maximum Acceptable Delta AI3	R/W
586	Maximum Acceptable Delta AI4	R/W
587	Maximum Rejection Time AI1	R/W
588	Maximum Rejection Time AI2	R/W
589	Maximum Rejection Time AI3	R/W
590	Maximum Rejection Time AI4	R/W
591	Sampling Frequency AI1 AI2	R/W
592	Sampling Frequency AI3 AI4	R/W
593	Digital input filter	R/W
594	Encoder/Counter type 1	R/W
595	Encoder/Counter type 2	R/W
596	Encoder/Counter type 3	R/W
597	Encoder/Counter type 4	R/W
598	Encoder preset 1 L	R/W
599	Encoder preset 1 H	R/W
600	Encoder preset 2 L	R/W
601	Encoder preset 2 H	R/W

Holding register	Name	Access
602	Encoder preset 3 L	R/W
603	Encoder preset 3 H	R/W
604	Encoder preset 4 L	R/W
605	Encoder preset 4 H	R/W
606	Type AO1	R/W
607	Type AO2	R/W
608	Lower limit AO1	R/W
609	Lower limit AO2	R/W
610	Upper limit AO1	R/W
611	Upper limit AO2	R/W
612	Error value AO1	R/W
613	Error value AO2	R/W
614	PTO1 output type	R/W
615	PTO2 output type	R/W
700	Encoder preset 1 H (BIS)	R/W
701	Encoder preset 1 L (BIS)	R/W
702	Encoder preset 2 H (BIS)	R/W
703	Encoder preset 2 L (BIS)	R/W
704	Encoder preset 3 H (BIS)	R/W
705	Encoder preset 3 L (BIS)	R/W
706	Encoder preset 4 H (BIS)	R/W
707	Encoder preset 4 L (BIS)	R/W

Input register	Name	Access
0	Value Ohm AI1	R
1	Value Ohm AI2	R
2	Value Ohm AI3	R
3	Value Ohm AI4	R
4	Encoder counter 1 L	R
5	Encoder counter 1 H	R
6	Encoder counter 2 L	R
7	Encoder counter 2 H	R
8	Encoder counter 3 L	R
9	Encoder counter 3 H	R
10	Encoder counter 4 L	R
11	Encoder counter 4 H	R
12	Encoder counter (1 s) 1 L	R
13	Encoder counter (1 s) 1 H	R
14	Encoder counter (1 s) 2 L	R
15	Encoder counter (1 s) 2 H	R
16	Encoder counter (1 s) 3 L	R
17	Encoder counter (1 s) 3 H	R
18	Encoder counter (1 s) 4 L	R
19	Encoder counter (1 s) 4 H	R
20	Encoder counter (100 ms) 1 L	R
21	Encoder counter (100 ms) 1 H	R
22	Encoder counter (100 ms) 2 L	R

Input register	Name	Access
23	Encoder counter (100 ms) 2 H	R
24	Encoder counter (100 ms) 3 L	R
25	Encoder counter (100 ms) 3 H	R
26	Encoder counter (100 ms) 4 L	R
27	Encoder counter (100 ms) 4 H	R
32	Value AI1	R
33	Value AI2	R
34	Value AI3	R
35	Value AI4	R
36	Error Flags	R
37	Cold junction 1 temperature	R
38	Cold junction 2 temperature	R
39	PWM running status PTO1	R
40	PWM running status PTO2	R
41	Digital inputs	R
100	Conversion AI1 L	R
101	Conversion AI1 H	R
102	Conversion AI2 L	R
103	Conversion AI2 H	R
104	Conversion AI3 L	R
105	Conversion AI3 H	R
106	Conversion AI4 L	R
107	Conversion AI4H	R
108	Conversion average AI1 L	R
109	Conversion average AI1 H	R
110	Conversion average AI2 L	R
111	Conversion average AI2 H	R
112	Conversion average AI3 L	R
113	Conversion average AI3 H	R
114	Conversion average AI4 L	R
115	Conversion average AI4H	R
150	Encoder counter 1 H (BIS)	R
151	Encoder counter 1 L (BIS)	R
152	Encoder counter 2 H (BIS)	R
153	Encoder counter 2 L (BIS)	R
154	Encoder counter 3 H (BIS)	R
155	Encoder counter 3 L (BIS)	R
156	Encoder counter 4 H (BIS)	R
157	Encoder counter 4 L (BIS)	R
158	Encoder counter (1 s) 1 H (BIS)	R
159	Encoder counter (1 s) 1 L (BIS)	R
160	Encoder counter (1 s) 2 H (BIS)	R
161	Encoder counter (1 s) 2 L (BIS)	R
162	Encoder counter (1 s) 3 H (BIS)	R
163	Encoder counter (1 s) 3 L (BIS)	R
164	Encoder counter (1 s) 4 H (BIS)	R
165	Encoder counter (1 s) 4 L (BIS)	R



















Input register	Name	Access
166	Encoder counter (100 ms) 1 H (BIS)	R
167	Encoder counter (100 ms) 1 L (BIS)	R
168	Encoder counter (100 ms) 2 H (BIS)	R
169	Encoder counter (100 ms) 2 L (BIS)	R
170	Encoder counter (100 ms) 3 H (BIS)	R
171	Encoder counter (100 ms) 3 L (BIS)	R
172	Encoder counter (100 ms) 4 H (BIS)	R
173	Encoder counter (100 ms) 4 L (BIS)	R
501	Active connections	R
502	Valid answers	R
503	CRC errors counter	R
504	Exception errors counter	R
505	TCP/IP connection errors counter	R
506	TCP/IP timeout errors counter	R

Coils	Name	Access
0	Digital Output Q 0.0	R/W
1	Digital Output Q 0.1	R/W
2	Digital Output Q 0.2	R/W
3	Digital Output Q 0.3	R/W
4	Digital Output Q 0.4	R/W
5	Digital Output Q 0.5	R/W
6	Digital Output Q 0.6	R/W
7	Digital Output Q 0.7	R/W
8	Digital Output I/Q 1.0	R/W
9	Digital Output I/Q 1.1	R/W
10	Digital Output I/Q 1.2	R/W
11	Digital Output I/Q 1.3	R/W
12	Digital Output I/Q 1.4	R/W
13	Digital Output I/Q 1.5	R/W
14	Digital Output I/Q 1.6	R/W
15	Digital Output I/Q 1.7	R/W

Discrete Inputs	Name	Access
0	Digital Input I 0.0	R
1	Digital Input I 0.1	R
2	Digital Input I 0.2	R
3	Digital Input I 0.3	R
4	Digital Input I 0.4	R
5	Digital Input I 0.5	R
6	Digital Input I 0.6	R
7	Digital Input I 0.7	R
8	Digital Input I/Q 1.0	R
9	Digital Input I/Q 1.1	R
10	Digital Input I/Q 1.2	R
11	Digital Input I/Q 1.3	R



12	Digital Input I/Q 1.4	R
13	Digital Input I/Q 1.5	R
14	Digital Input I/Q 1.6	R
15	Digital Input I/Q 1.7	R



5.4 Significato delle spie di stato (Led)

LED RUN	LED COM	Stato	Comunicazione
 BLINKING 10Hz		Errore di inizializzazione, nessuna inizializzazione	Nessuna comunicazione
 BLINKING 1Hz		Errore offline	Qualsiasi comunicazione
		In attesa di collegamento	Nessuna comunicazione
		Modbus TCP/IP attivo	Comunicazione Modbus TCP/IP attiva
	 BLINKING	Modbus RTU attivo	Comunicazione Modbus RTU attiva
 BLINKING		Lettura/Scrittura della memoria	Comunicazione con MYPISYS LAB
		Modbus TCP/IP attivo, con errori di comunicazione, impossibile collegarsi al server remoto	Comunicazione Modbus TCP/IP in errore
	 BLINKING	Modbus RTU attivo, con errori di comunicazione	Comunicazione Modbus RTU in errore
 BLINKING 1Hz		Inizializzazione comunicazione con il server remoto/ Aggiornamento firmware	Comunicazione HTTPS attiva

5.4.1 Led I/O



LED A0x	Stato
	Analog Output attivo
	Analog Output non attivo

LED PTOx	Stato
	PTO Output/PWM attivo
	PTO Output/PWM non attivo

LED A1x	Stato
	Segnale in ingresso
 BLINKING	Ingresso in errore, errore di configurazione ingresso o sonda danneggiata
	Nessun segnale rilevato





















































LED Q.x	Stato
	Digital Output attivo
	Digital Output non attivo

LED I.x	Stato
	Segnale in ingresso
	Nessun segnale rilevato

LED I/Q.x	Stato
	Segnale in ingresso / Digital Output attivo
	Nessun segnale rilevato / Digital Output non attivo

LED CONFIRM	Stato
	Tasto premuto
 BLINKING	Parametri di default caricati

5.4.2 Led di errore hardware

LED E1	LED E2	LED E3	LED E4	Err. code	Descrizione
				0	Nessun errore
				1	Errore Parameters, impossibile caricare i parametri dalla memoria
				2	Errore Status, impossibile caricare i dati di stato dalla memoria
				3	Errore Calibration, impossibile caricare i dati di taratura dalla memoria
				4	Errore Constants, impossibile caricare i dati costanti dalla memoria
				5	Errore Calibration none, calibrazioni I/O non presenti
				6	Errore Out of Range, parametro fuori range
				7	Errore memory, errore hardware su memoria parametri I/O
				8	Errore Cold junction, rottura giunto freddo
				9	Errore power supply, tensione di alimentazione troppo bassa
				10	Errore memory, errore hardware su memoria parametri
				11	Errore Ethernet, impossibile configurare la porta di comunicazione
				12	Errore su I/O integrato

5.5 Aggiornamento firmware

Per aggiornare il firmware del dispositivo all'ultima versione disponibile:

- collegare il dispositivo ad una rete ethernet con server DHCP, e con accesso ad Internet oppure configurare correttamente l'indirizzo DNS e GATEWAY per accedere ad internet
- nel caso si utilizzi una rete DHCP, impostare il parametro **DHCP enable** a YES • avviare la procedura di aggiornamento premendo il tasto **Update** dal menu **Utilities**.

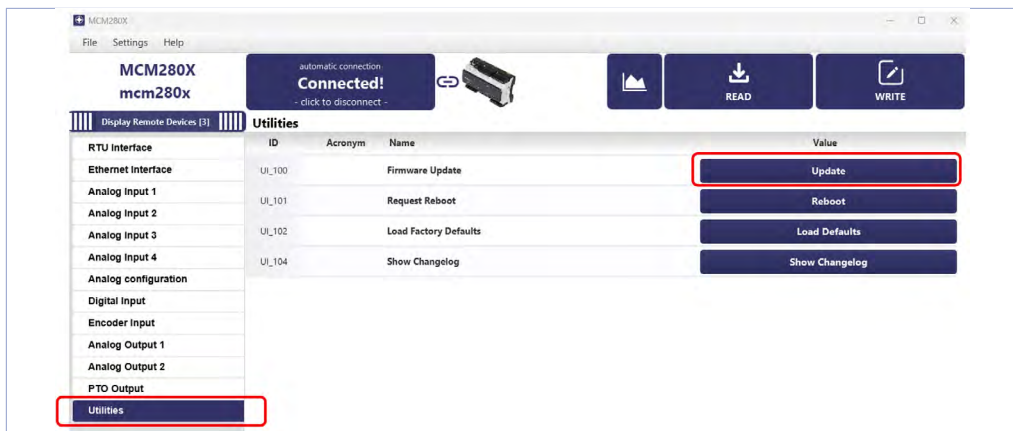

5.6 Caricamento valori di default

In caso fosse necessario ripristinare il modulo alle impostazioni di fabbrica, seguire la procedura seguente.



- Accendere il modulo MCM280X
- Aprire lo sportellino frontale
- Premere e tenere premuto il pulsante S1 (presente nella parte inferiore sinistra della scheda sotto allo sportellino) per almeno 10 secondi
- A ripristino completato, il led verde CONFIRM lampeggerà
- Rilasciare il pulsante S1
- Spegnerne e riaccendere il modulo MCM280X.

Di seguiti i parametri di fabbrica:

Parametro	Default di fabbrica
RTU Baudrate	115200
RTU frame format	data: 8 bits stop: 1 bit parity: none
RTU time-out	100
RTU slave id	247
DHCP enable	NO
Modbus port	502
Bridge enable	NO
IP address	192.168.0.175
Subnet mask	255.255.0.0
Gateway	0.0.0.0
Dns	0.0.0.0
Enable idle timeout	NO
TCP/IP server timeout	0
Time between messages	0
Device name characters	mcm280

Parametro	Default di fabbrica
Offline timeout	0
Offline outputs bitmask	0
Enable offline	NO
Offline AO1 value	0
Offline AO2 value	0
Sensor type AI1	Disable
Sensor type AI2	Disable
Sensor type AI3	Disable
Sensor type AI4	Disable
Temperature Unit Setting	°C
Lower limit AI1	0
Lower limit AI2	0
Lower limit AI3	0
Lower limit AI4	0
Upper limit AI1	1000
Upper limit AI2	1000
Upper limit AI3	1000
Upper limit AI4	1000
Potentiometer value AI1	10 kΩ
Potentiometer value AI2	10 kΩ
Potentiometer value AI3	10 kΩ
Potentiometer value AI4	10 kΩ
Linear overrange limit AI1	OFF
Linear overrange limit AI2	OFF
Linear overrange limit AI3	OFF
Linear overrange limit AI4	OFF
Offset calibration AI1	0
Offset calibration AI2	0
Offset calibration AI3	0
Offset calibration AI4	0
Gain calibration AI1	0.0
Gain calibration AI2	0.0
Gain calibration AI3	0.0
Gain calibration AI4	0.0
Filter AI1	10
Filter AI2	10
Filter AI3	10
Filter AI4	10
Maximum Acceptable Delta AI1	10.0
Maximum Acceptable Delta AI2	10.0
Maximum Acceptable Delta AI3	10.0
Maximum Acceptable Delta AI4	10.0
Maximum Rejection Time AI1	1.0
Maximum Rejection Time AI2	1.0
Maximum Rejection Time AI3	1.0
Maximum Rejection Time AI4	1.0
Sampling Frequency AI1 AI2	17 Hz
Sampling Frequency AI3 AI4	17 Hz
Digital input filter	5 ms
Encoder/Counter type 1	Disable
Encoder/Counter type 2	Disable
Encoder/Counter type 3	Disable

Parametro	Default di fabbrica
Encoder/Counter type 4	Disable
Encoder preset 1	0
Encoder preset 2	0
Encoder preset 3	0
Encoder preset 4	0
Type AO1	0 - 10V
Type AO2	0 - 10V
Lower limit AO1	0
Lower limit AO2	0
Upper limit AO1	1000
Upper limit AO2	1000
Error value AO1	0
Error value AO2	0
PTO1 output type	ON/OFF
PTO2 output type	ON/OFF

6 Funzionalità

6.1 Controllo dinamico del PWM

Per utilizzare il controllo dinamico delle uscite PTO in modalità PWM, è necessario configurare l'uscita selezionando la modalità **PWM** nel parametro **PTOx Output Mode**.

Impostando sul registro **Commands PTOx** il comando **Start PWM Dynamic Control**, l'uscita genera un'onda quadra con:

- Frequenza pari al valore del registro **Frequency PWM PTOx**
- Duty Cycle pari al valore del registro **Duty Cycle PTOx**

Una volta attivata l'uscita, è possibile modificare in tempo reale i valori del PWM aggiornando i registri dedicati. In questo modo è possibile controllare dinamicamente il segnale in uscita, ad esempio per generare rampe di accelerazione o decelerazione.

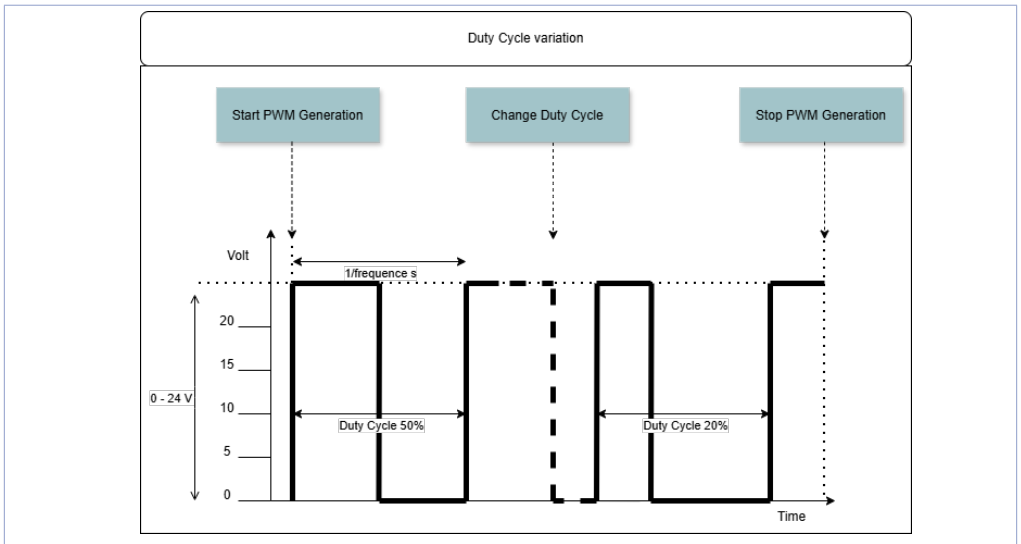

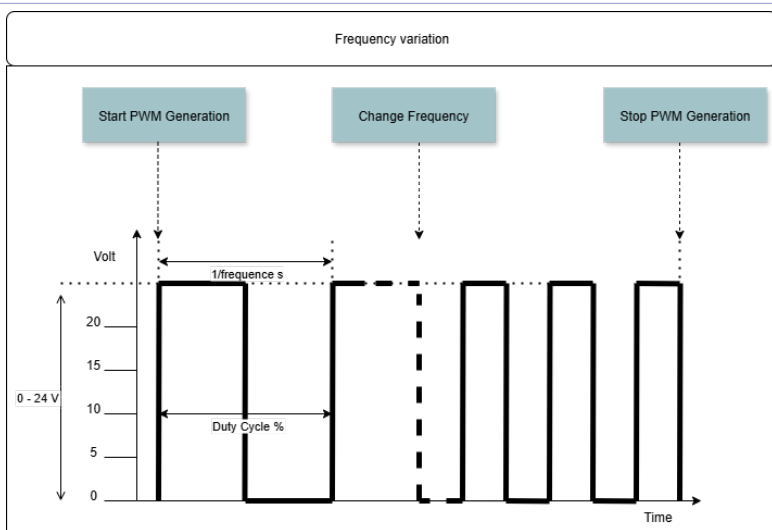

6.2 Controllo dell'AO

Per controllare le uscite AO, è necessario configurare con i parametri **Lower limit AOx**, **Upper limit AOx**, **Error value AOx**.

Dopo aver configurato l'uscita scrivere sul registro corrispondente Value AOx

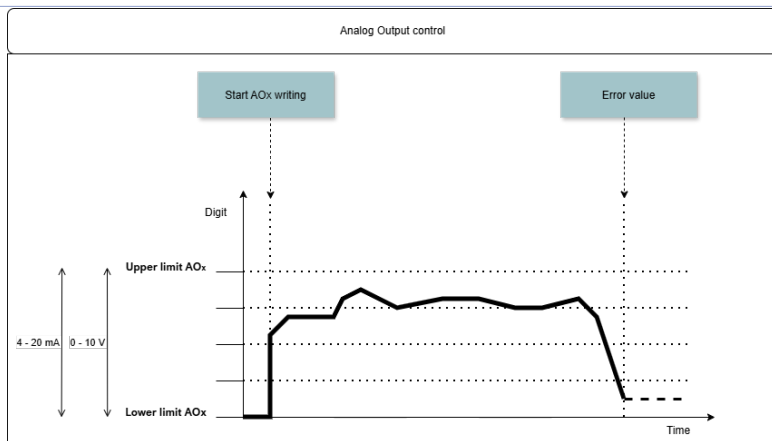

6.3 Bridge mode

Nella modalità **Bridge** il modulo funge da porte Modbus TCP/IP con tutti gli slave collegati.

Per utilizzare la modalità Bridge, è necessario configurare il parametro **Bridge enable** a ON.

Dopo aver riavviato il modulo, collegare gli slave Modbus RTU alla COM1.

Per comunicare con gli slave basterà interrogare i registri all'indirizzo IP del MCM280 con ID Modbus degli slave

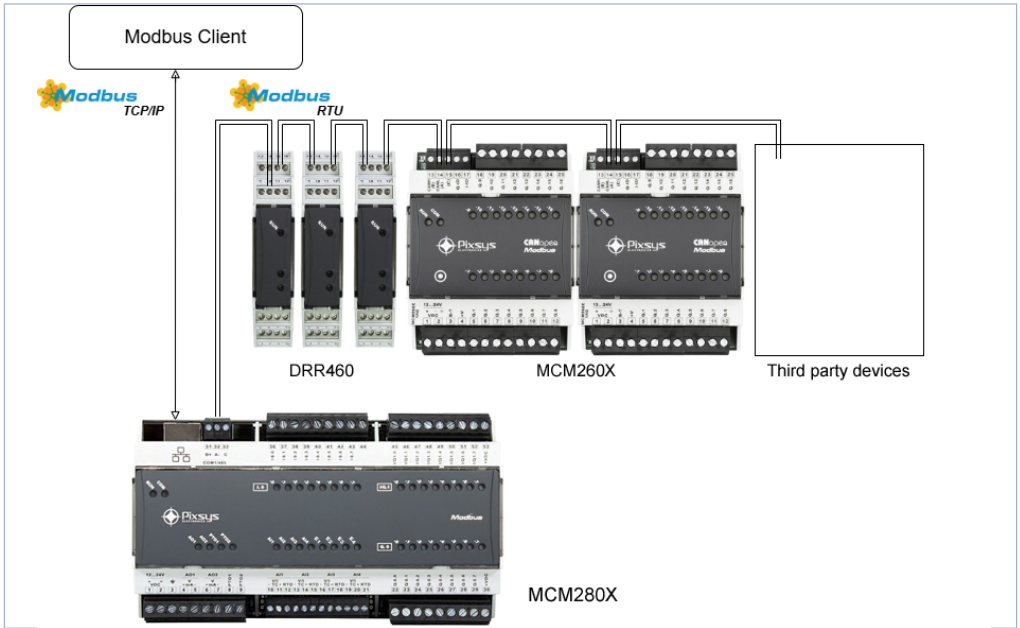

6.4 System offline

Questa modalità di funzionamento NON sostituisce le protezioni elettriche obbligatorie né costituisce, di per sé, un sistema di sicurezza. L'utilizzo del dispositivo senza adeguate precauzioni, protezioni e controlli conformi ai requisiti normativi di sicurezza elettrica e di macchina può comportare rischi per persone e apparecchiature.

Per utilizzare la funzionalità di Offline, è necessario configurare i seguenti parametri:

- Offline Timeout
 - Offline Outputs Bitmask
 - Offline AO1 value
 - Offline AO2 value
 - Enable Offline
- Se il valore del parametro Offline Timeout è maggiore di zero e il parametro Enable Offline è impostato a YES, il System Offline viene abilitato.

Il System Offline si attiva alla prima connessione Modbus TCP/IP. Da quel momento, il sistema verifica periodicamente la variazione del valore del registro Offline counter (Holding Register 100).

- Se il contenuto del registro non varia entro il tempo di timeout configurato, il sistema rileva una condizione di Offline e attiva le uscite digitali e analogiche secondo quanto definito dal parametro Offline Outputs Bitmask, Offline AO1 value, Offline AO2 value

Le uscite mantengono lo stato impostato fino alla rilevazione di una nuova variazione del valore nel registro Offline counter. A seguito di tale variazione, il controllo dello stato delle uscite risulterà nuovamente disponibile.

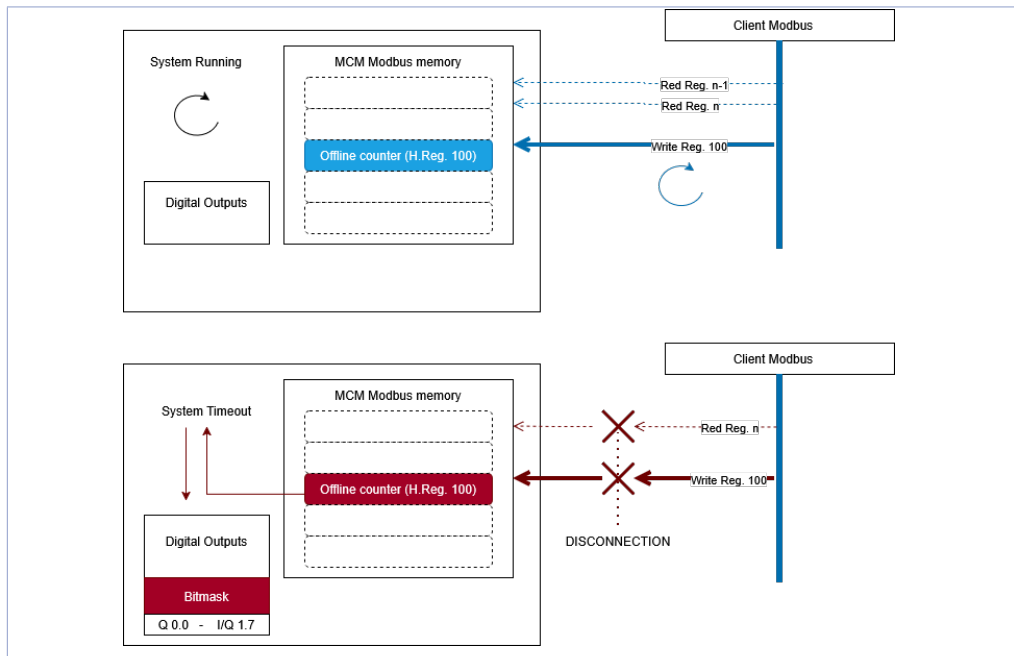

7 Registri di controllo

7.1 Holding registers

Address: -0

En/Status PTO Outputs

Default

Descrizione

0

Maschera a bit per comandare le uscite PTO in modalità ON/OFF.

Range di valori

Se le uscite sono impostate come PWM comunica lo stato attivo delle uscite.

0 - 2

(vedi Parametri **PTO1 output mode**, **PTO2 output mode**)

BIT0: PTO1

BIT1: PTO2

Address: -1 -2

Value AOx

Default

Descrizione

0

Valore di controllo dell'uscita analogica AOx, in base al parametro di configurazione **AOx mode** può essere configurata per funzionare in **0-10 Volt** oppure in **4-20mA**.

Range di valori

Si può impostare il valore che l'uscita genera in caso di errore o anomalia utilizzando il parametro **Error value AOx**.

Lower limit AO1 - Upper limit AO1

o

Lower limit AO2 - Upper limit AO2

Address: -3 -4 -5 -6**Commands Encoder x****Default**

0

Range di valori

Lower limit AO1 - Upper limit AO1

0

Lower limit AO2 - Upper limit AO2

DescrizioneMaschera a bit per inviare i comandi al **Encoder x**

I bit vengono automaticamente caricati con valore zero dopo l'esecuzione del comando.

BIT0: Load preset value**BIT1:** Load preset value during next Z pulseIl valore di **preset** viene impostato sul parametro **Encoder preset x****Address: -11 -12 -13 -14****Frequency PWM PTOx****Default**

2000

Range di valori [Hz]

1 - 20000

DescrizioneValore della frequenza dell'onda quadra generata dall'uscita **PTOx** quando è configurata come **PWM** (vedi parametro **PTO1 output mode** o **PTO2 output mode**)**PTO1**

Low part: register 11

High part: register 12

PTO2

Low part: register 13

High part: register 14

Address: -15 -16**Duty Cycle PTOx****Default**

50.00

Range di valori [%]

0.00 - 100.00

DescrizioneValore del Duty Cycle dell'onda quadra generata dall'uscita **PTOx** quando è configurata come **PWM** (vedi parametro **PTO1 output mode** o **PTO2 output mode**)**Address: -17 -18****Commands PTOx****Default**

0

Range di valori

10 - 11

DescrizioneComandi per attivare e disattivare l'uscita **PTOx** in modalità **PWM****10:** Start PWM Dynamic control**11:** Stop PWM**Address: -19****Digital output****Default**

0

Range di valori

0 - 65535

Descrizione

Bit mask per comandare le uscite digitali

BIT0: Q.0.0**BIT1:** Q.0.1

...

BIT8: Q.1.0**BIT9:** Q.1.1

Address: -54 -55 -56 -57	Frequency PWM PTOx (BIS)
Default 1	Descrizione Copia dei registri Frequency PWM PTOx ma con l'ordine delle word invertito
Range di valori [digit] 1 - 20000	PTO1 Low part: register 55 High part: register 54 PTO2 Low part: register 57 High part: register 56

Address: -100	Offline counter
Default 0	Descrizione Se il parametro Offline Timeout è maggiore di 0, e Enable offline è impostato a YES dopo la prima connessione Modbus TCP/IP il sistema verifica periodicamente la variazione del valore di questo registro. Se il valore rimane invariato per un tempo superiore al timeout impostato, viene rilevata una condizione di Offline e le uscite vengono forzate secondo quanto definito dal parametro Offline Outputs Bitmask , Offline AO1 value , Offline AO2 value
Range di valori 1 - 65535	Per ulteriori dettagli, fare riferimento al paragrafo 6.4 System Offline.

7.2 Input registers

Address: -0 -1 -2 -3	Value Ohm Alx
Default -	Descrizione Valore in Ohm dell'ingresso analogico nel caso di sensori NI, PT, NTC, PTC, Potentiometer
Range di valori 0 - 65535	

Address: -4 -5 -6 -7 -8 -9 -10 -11	Encoder counter x
Default -	Descrizione Conteggio encoder/counter rappresentato come valore a 32 bit.
Range di valori 0 - 4294967295	Encoder 1 Low part: register 4 High part: register 5 Encoder 2 Low part: register 6 High part: register 7 Encoder 3 Low part: register 8 High part: register 9 Encoder 4 Low part: register 10 High part: register 11

Address: -12 -13 -14 -15
-16 -17 -18 -19

Encoder counter (1 s) x

Default

-

Range di valori

0 - 4294967295

Descrizione

Conteggio encoder/counter rappresentato come valore a 32 bit. Dato aggiornato ogni 1.0 s.

Encoder 1

Low part: register 12

High part: register 13

Encoder 2

Low part: register 14

High part: register 15

Encoder 3

Low part: register 16

High part: register 17

Encoder 4

Low part: register 18

High part: register 19

Address: -20 -21 -22 -23
-24 -25 -26 -27

Encoder counter (100 ms) x

Default

-

Range di valori

0 - 4294967295

Descrizione

Conteggio encoder/counter rappresentato come valore a 32 bit. Dato aggiornato ogni 100 ms.

Encoder 1

Low part: register 20

High part: register 21

Encoder 2

Low part: register 22

High part: register 23

Encoder 3

Low part: register 24

High part: register 25

Encoder 4

Low part: register 26

High part: register 27

Address: -32 -33 -34 -35

Value Alx

Default

-

Range di valori

-32768 - +32768

Descrizione

Valore degli ingressi analogici.

Nel caso di configurazione con sensori di temperatura il valore è espresso in decimi di grado.

In presenza di condizioni di errore

- ingresso fuori range,
- cortocircuito,
- circuito aperto,

verranno restituiti i codici di errore specifici previsti dal sistema.

Corto: -32768

Aperto 32767

Per errore Alx fuori range fare riferimento al registro **Error Flags**.

In caso di errore sugli ingressi i led corrispondenti segnaleranno l'errore come descritto nelle tabelle **7.4.1 Led I/O**

Address: -36

Error Flags

Default

-

Range di valori

0 - 65535

Descrizione

Flags di errore hardware relativi agli I/O

BIT0: Errore Parameters, impossibile caricare i parametri dalla memoria

BIT1: Errore Status, impossibile caricare i dati di stato dalla memoria

BIT2: Errore Calibration, impossibile caricare i dati di taratura dalla memoria

BIT3: Errore Constants, impossibile caricare i dati costanti dalla memoria

BIT4: Errore Calibration none, calibrazioni I/O non presenti

BIT5: Errore Out of Range, parametro fuori range

BIT6: Errore memory, errore hardware su memoria parametri I/O

BIT7: Errore Cold junction, rottura giunto freddo

BIT8: Errore power supply, tensione di alimentazione troppo bassa

BIT9: AI1 fuori range

BIT10: AI2 fuori range

BIT11: AI3 fuori range

BIT12: AI4 fuori range

Address: -37 -38

Cold junction temp x

Default

-

Range di valori

0 - 65535

Descrizione

Temperatura rilevata dal giunto freddo.

Utilizzata per la compensazione dell'errore per una corretta lettura della temperatura assoluta

Address: -39 -40

PWM running status PTOx

Default

-

Descrizione

Stato delle uscite PTO

Range di valori

0 - 1

0: PWM OFF

1: PWM running

Address: -41

Digital Inputs

Default

-

Descrizione

Bit mask per leggere gli ingressi digitali

Range di valori

0 - 65535

BIT0: I.0.0

BIT1: I.0.1

...

BIT8: I.1.0

BIT9: I.1.1

Address: -100 -101 -102 -103
-104 -105 -106 -107

Conversion Alx

Default

-

Descrizione

Segnale analogico convertito

Range di valori

0 - 4294967295

AI1

Low part: register 100

High part: register 101

AI2

Low part: register 102

High part: register 103

AI3

Low part: register 104

High part: register 105

AI4

Low part: register 106

High part: register 107

Address: -108 -109 -110 -111
-112 -113 -114 -115

Conversion average Alx

Default

-

Descrizione

Media del segnale analogico convertito

Range di valori

0 - 4294967295

AI1

Low part: register 108

High part: register 109

AI2

Low part: register 110

High part: register 111

AI3

Low part: register 112

High part: register 113

AI4

Low part: register 114

High part: register 115

Address: -150 -151 -152 -153
-154 -155 -156 -157

Encoder counter x (BIS)

Default

-

Range di valori

0 - 4294967295

Descrizione

Copia dei registri Encoder counter x ma con l'ordine delle word invertito

Encoder 1

Low part: register 151

High part: register 150

Encoder 2

Low part: register 153

High part: register 152

Encoder 3

Low part: register 155

High part: register 154

Encoder 4

Low part: register 157

High part: register 156

Address: -158 -159 -160 -161
-162 -163 -164 -165

Encoder counter (1 s) x (BIS)

Default

-

Range di valori

0 - 4294967295

Descrizione

Copia dei registri Encoder counter (1 s) x ma con l'ordine delle word invertito

Encoder 1

Low part: register 159

High part: register 158

Encoder 2

Low part: register 161

High part: register 160

Encoder 3

Low part: register 163

High part: register 162

Encoder 4

Low part: register 165

High part: register 164

Address: -166 -167 -168 -169
-170 -171 -172 -173

Encoder counter (100 ms) x (BIS)

Default

-

Range di valori

0 - 4294967295

Descrizione

Copia dei registri Encoder counter (100 ms) x ma con l'ordine delle word invertito

Encoder 1

Low part: register 167

High part: register 166

Encoder 2

Low part: register 169

High part: register 168

Encoder 3

Low part: register 171

High part: register 170

Encoder 4

Low part: register 173

High part: register 172

Address: -501	Active connection
Default -	Descrizione Numero di connessioni attive sul dispositivo
Range di valori 0 - 65535	
Address: -502	Valid answers
Default -	Descrizione Numero risposte valide inviate al client Modbus TCP/IP o risposte valide ricevute sull'interfaccia seriale
Range di valori 0 - 65535	
Address: -503	CRC errors counter
Default -	Descrizione Numero di risposte ricevute con errori CRC sull'interfaccia seriale
Range di valori 0 - 65535	
Address: -504	Exception errors counter
Default -	Descrizione Numero di eccezioni inviate al client Modbus TCP/IP o risposte ricevute sull'interfaccia seriale contenenti eccezioni
Range di valori 0 - 65535	
Address: -505	TCP/IP errors counter
Default -	Descrizione Numero di errori o disconnessioni rilevate durante la connessione TCP/IP
Range di valori 0 - 65535	
Address: -506	TCP/IP timeout errors counter
Default -	Descrizione Numero di connessione chiuse allo scadere del time-out impostato vedi parametri: Enable idle timeout e Server Idle timeout
Range di valori 0 - 65535	

7.3 Coils

Address:

-0	Digital Output Q 0.0
-1	Digital Output Q 0.1
-2	Digital Output Q 0.2
-3	Digital Output Q 0.3
-4	Digital Output Q 0.4
-5	Digital Output Q 0.5
-6	Digital Output Q 0.6
-7	Digital Output Q 0.7
-8	Digital Output I/Q 1.0
-9	Digital Output I/Q 1.1
-10	Digital Output I/Q 1.2
-11	Digital Output I/Q 1.3
-12	Digital Output I/Q 1.4
-13	Digital Output I/Q 1.5
-14	Digital Output I/Q 1.6
-15	Digital Output I/Q 1.7

Information Al riavvio le uscite vengono sempre azzerate

7.4 Discrete Inputs

Address:

-0	Digital Input I 0.0
-1	Digital Input I 0.1
-2	Digital Input I 0.2
-3	Digital Input I 0.3
-4	Digital Input I 0.4
-5	Digital Input I 0.5
-6	Digital Input I 0.6
-7	Digital Input I 0.7
-8	Digital Input I/Q 1.0
-9	Digital Input I/Q 1.1
-10	Digital Input I/Q 1.2
-11	Digital Input I/Q 1.3
-12	Digital Input I/Q 1.4
-13	Digital Input I/Q 1.5
-14	Digital Input I/Q 1.6
-15	Digital Input I/Q 1.7

8 Parametri e registri di configurazione

8.1 Holding registers

Address: -501	RTU Baudrate
Default 8 (115200)	Descrizione Definisce la velocità di comunicazione della porta RS485
Range di valori 1 - 8	1: 2400bps 2: 4800bps 3: 9600bps 4: 19200bps 5: 28800bps 6: 38400bps 7: 57600bps 8: 115200bps
Address: -502	RTU Frame format
Default 1 (data: 8 bits stop: 1 bit parity: none)	Descrizione Definisce il formato dei dati utilizzato sulla porta RS485
Range di valori 1 - 6	1: data: 8 bits stop: 1 bit parity: none 2: data: 8 bits stop: 1 bit parity: even 3: data: 8 bits stop: 1 bit parity: odd 4: data: 8 bits stop: 2 bits parity: none 5: data: 8 bits stop: 2 bits parity: even 6: data: 8 bits stop: 2 bits parity: odd
Address: -503	RTU Time out
Default 100	Descrizione Definisce il tempo massimo di attesa della risposta dal modulo Modbus RTU in ms
Range di valori [ms] 10 - 10000	
Address: -504	ID Modbus
Default 247	Descrizione Definisce l'ID Modbus del modulo
Range di valori 1 - 247	
Address: -505	DHCP enable
Default 1	Descrizione Abilitazione della modalità DHCP
Range di valori 1 - 2	1: NO 2: YES

Address: -506	Modbus Port
Default 502	Descrizione Definisce la porta Ethernet di comunicazione
Range di valori 1 - 12000	
Address: -507	Bridge Mode
Default 1	Descrizione Abilitazione della modalità Bridge
Range di valori 1 - 2	1: NO 2: YES
Address: -510 -511 -512 -513	IP address
Default 192.168.0.175	Descrizione Imposta l'indirizzo IP del modulo
	First part: register 510 Second part: register 511 Third part: register 512 Fourth part: register 513
Address: -514 -515 -516 -517	Subnet mask
Default 255.255.0.0	Descrizione Imposta la Subnet mask del modulo
	First part: register 514 Second part: register 515 Third part: register 516 Fourth part: register 517
Address: -518 -519 -520 -521	Gateway
Default 0.0.0.0	Descrizione Imposta il Gateway del modulo
	First part: register 518 Second part: register 519 Third part: register 520 Fourth part: register 521
Address: -522 -523 -524 -525	DNS
Default 0.0.0.0	Descrizione Imposta il DNS del modulo
	First part: register 522 Second part: register 523 Third part: register 524 Fourth part: register 525

Address: -526

Enable idle timeout

Default

1

Range di valori

1 - 2

Descrizione

Abilita la disconnessione automatica del client TCP/IP nel caso in cui non venga rilevato traffico di rete in ingresso per un determinato intervallo di tempo

1: NO

2: YES

Address: -527

Server idle timeout

Default

600

Range di valori

1 - 7200

Descrizione

Intervallo di tempo di inattività, espresso in secondi, al termine del quale il server effettua la disconnessione automatica del client TCP/IP.

Il parametro è attivo solo quando l'opzione Enable Idle Timeout è abilitata.

Address: -528

Time between messages

Default

0

Range di valori

1 - 10000

Descrizione

Intervallo di tempo aggiuntivo inserito tra la trasmissione di un messaggio e l'invio del messaggio successivo. Questo parametro consente di regolare la temporizzazione delle comunicazioni, riducendo il carico sulla linea.

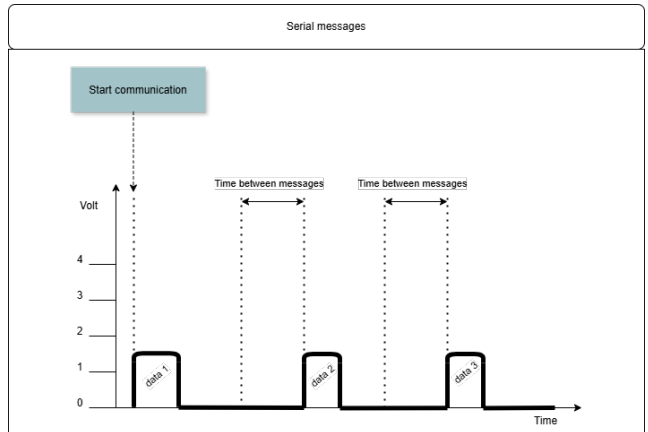

Address: -530 -531 -532 -534
-535 -536 -537 -538
-539 -540 -541

Device name

Default

mcm280x

Descrizione

Imposta il nome del modulo visibile su MyPixsys Lab

Caratteri 1-2: register 530
Caratteri 3-4: register 531
Caratteri 5-6: register 532
Caratteri 7-8: register 533
Caratteri 9-10: register 534
Caratteri 11-12: register 535
Caratteri 13-14: register 536
Caratteri 15-16: register 537
Caratteri 17-18: register 538
Caratteri 19-20: register 539
Caratteri 21-22: register 540
Caratteri 23-24: register 541

Address: -542

Offline timeout

Default

0

Range di valori

0.00 - 600.00

Descrizione

Intervallo di inattività, espresso in secondi, al termine del quale il dispositivo attiva le uscite digitali secondo la configurazione impostata dal parametro **Offline outputs bitmask**, **Offline AO1**, e **Offline AO2**

Address: -543

Offline outputs bitmask

Default

0

Range di valori

1 - 65535

Descrizione

Maschera a bit che definisce lo stato delle uscite digitali in caso di attivazione dell'Offline di sistema

Address: -544

Enable offline

Default

1

Range di valori

1 - 2

Descrizione

Abilitazione della modalità offline

1: NO
2: YES

Address: -545

Offline AO1

Default

0

Range di valori

-32768 - 32767

Descrizione

Valore dell'uscita analogica AO1 in caso di attivazione dell'Offline di sistema

Address: -546

Offline AO2

Default

0

Descrizione

Valore dell'uscita analogica AO2 in caso di attivazione dell'Offline di sistema

Range di valori

-32768 - 32767

Address: -550 -551 -522 -553

Sensor type Alx

Default

0

Descrizione

Configurazione dell'ingresso analogico in base al tipo di sensore:

Range di valori

0 - 23

Sensor type AI1: register 550

Sensor type AI2: register 551

Sensor type AI3: register 552

Sensor type AI4: register 553

0: Disable

1: Tc K -260 °C..1360 °C

2: Tc S -40 °C..1760 °C

3: Tc R -40 °C..1760 °C

4: Tc J -200 °C..1200 °C

5: Tc T -260 °C..400 °C

6: Tc E -260 °C..980 °C

7: Tc N -260 °C..1280 °C

8: Tc B 100 °C..1820 °C

9: PT100 -100 °C..600 °C

10: NI100 -60 °C..180 °C

11: NTC-10K -40 °C..125 °C

12: PTC-1K -50 °C..150 °C

13: PT500 -100 °C..600 °C

14: PT1000 -100 °C..600 °C

15: 0..1 V

16: 0..5 V

17: 0..10 V

18: 0.200 mA

19: 4..20 mA

20: 0..60 mA

21: Potentiometer (vedi Potentiometer value Alx)

22: Count PGA 64

23: Count PGA 128

Address: -554

Temperature measurement unit

Default

0

Descrizione

Imposta l'unità di misura della temperatura

Range di valori

0 - 2

0: Celsius

1: Fahrenheit

2: Kelvin

Address: -555 -556 -557 -558

Default

0

Range di valori [digit]

-32768 - +32767

Lower limit A1x

Descrizione

Limite inferiore dell'ingresso analogico **A1x** (applicabile esclusivamente a segnali normalizzati).

Nel caso di ingresso 4...20 mA il valore è associato a 4 mA

Address: -559 -560 -561 -562

Default

1000

Range di valori [digit]

-32768 - +32767

Upper limit A1x

Descrizione

Limite superiore dell'ingresso analogico **A1x** (applicabile esclusivamente a segnali normalizzati).

Nel caso di ingresso 4...20 mA il valore è associato a 20 mA

Address: -563 -564 -565 -566

Default

10

Range di valori [kΩ]

1 - 150

Potentiometer value A1x

Descrizione

Valore del potenziometro connesso all'ingresso **A1x** nel caso in cui il relativo parametro **Sensor type A1x** sia impostato con **Potentiometer**

Address: -567 -568 -569 -570

Default

0

Range di valori

0 - 1

Linear overrange limit A1x

Descrizione

Abilita l'overrange dell'ingresso analogico **A1x** in modalità lineare, consentendo al processo di superare i limiti nominali, impostati su **Lower limit A1x**, e **Upper limit A1x**

0: OFF
1: ON

Address: -571 -572 -573 -574

Default

0

Range di valori

-10000 - +10000

Offset calibration A1x

Descrizione

Valore che viene sottratto o sommato al valore corrispondente di **A1x**

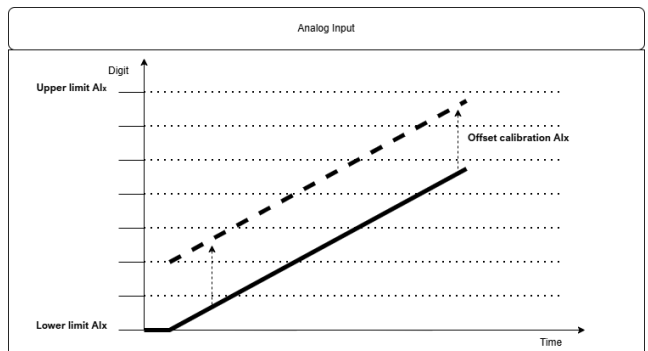

Address: -575 -576 -577 -578

Gain calibration Alx

Default

0

Range di valori [%]

-1000 - +1000

Descrizione

Valore che viene moltiplicato per il valore corrispondente di Alx

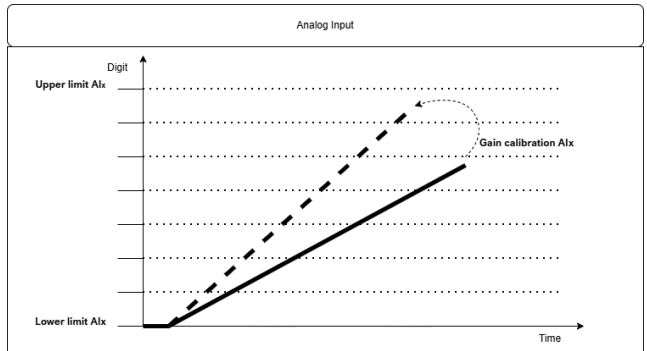

Address: -579 -580 -581 -582

Filter Alx

Default

10

Range di valori

1 - 50

Descrizione

Stabilizza il valore dell'ingresso analogico definendo il numero di campionamenti utilizzati per la media del processo.

Address: -583 -584 -585 -586

Maximum Acceptable Delta Alx

Default

10.0

Range di valori [digit] o [0.1 °C]

1 - 32767

Descrizione

Definisce il valore assoluto massimo consentito tra il valore di processo attuale e il nuovo campionamento affinché quest'ultimo sia considerato valido. Se il delta rientra nel limite, il campionamento viene inserito nella media gestita dal parametro **Filter Alx**; in caso contrario, viene scartato.

Address: -587 -588 -589 -590

Maximum Rejection Time Alx

Default

1.0

Range di valori [0.1s]

1 - 200

Descrizione

Definisce il tempo massimo durante il quale i campionamenti dell'ingresso analogico possono essere scartati se valutati non accettabili (vedi **Maximum Acceptable Delta Alx**)
Allo scadere di tale intervallo, qualsiasi nuovo campionamento viene considerato valido e accettato dal processo.

Address: -591 -592**Sampling Frequency Alx Aly****Default**

5

Range di valori

0-13

Descrizione

Frequenza di campionamento del convertitore analogico digitale. Frequenze più basse stabilizzano il valore letto, ma rallentano l'aggiornamento del dato.

Frequenze più alte aumentano la velocità di campionamento a scapito della stabilità del valore acquisito.

Sampling Frequency AI1 AI2: register 591

Sampling Frequency AI3 AI4: register 592

0:	4 Hz
1:	6 Hz
2:	8 Hz
3:	10 Hz
4:	12 Hz
5:	17 Hz
6:	20 Hz
7:	33 Hz
8:	39 Hz
9:	50 Hz
10:	62 Hz
11:	123 Hz
12:	242 Hz
13:	470 Hz

Address: -593**Digital input filter****Default**

5

Range di valori [ms]

0 - 250

Descrizione

Durata minima di stabilità dell'ingresso digitale necessaria per la validazione del segnale.

Address: -594 -595 -596 -597**Encoder/Counter type x****Default**

0

Range di valori

0 - 6

Descrizione

Imposta la modalità di funzionamento dell'ingresso encoder o counter.

0:	Disable
1:	Encoder x2 phase A-B
2:	Encoder x4 phase A-B
3:	Encoder x2 phase A-B-Z
4:	Encoder x4 phase A-B-Z
5:	Counter Up
6:	Counter Down (Non disponibile per Encoder 4)

Address: -598 -599 -600 -601
-602 -603 -604 -605

Encoder preset x

Default

0

Range di valori [digit]

-2147483648 - 2147483647

Descrizione

Valore che viene caricato nei registri contatori dell'encoder x quando viene inviato il relativo comando.

Il valore è a 32 bit ed è suddiviso in due registri a 16 bit.

Encoder 1

Low part: register 598

High part: register 599

Encoder 2

Low part: register 600

High part: register 601

Encoder 3

Low part: register 602

High part: register 603

Encoder 4

Low part: register 604

High part: register 605

Address: -606 -607

AOx mode

Default

0

Range di valori

0 - 1

Descrizione

Seleziona la modalità di funzionamento dell'uscita analogica AOx

0 = 0 - 10 Volt

1 = 4 - 20 mA

Address: -608 -609

Lower limit AOx

Default

0

Range di valori [digit]

-32768 - +32767

Descrizione

Limite inferiore dell'uscita AOx

Il valore è associato a 0V o 4mA in base alla configurazione

Address: -610 -611

Upper limit AOx

Default

1000

Range di valori [digit]

-32768 - +32767

Descrizione

Limite superiore dell'uscita AOx

Il valore è associato a 10V o 20mA in base alla configurazione

Address: -612 -613

Error value AOx

Default

0

Range di valori [digit]

Lower limit AO1- Upper limit AO1

o

Lower limit AO2- Upper limit AO2

Descrizione

Valore dell'uscita analogica AOx in caso di errore o anomalia

Default

0

Descrizione

Seleziona la modalità di funzionamento dell'uscita PTOx.

Range di valori

0 - 2

0 = ON/OFF

2 = PWM

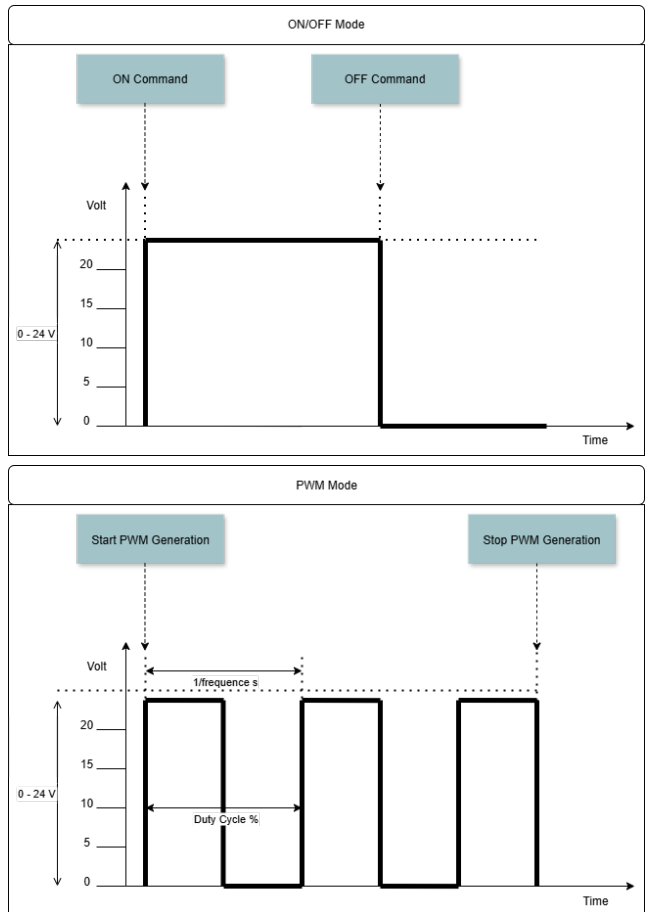

Address: -700 -701 -702 -703
-704 -705 -706 -707

Encoder preset x (BIS)

Default

0

Range di valori [digit]

-2147483648 - 2147483647

Descrizione

Copia dei registri Encoder preset x ma con l'ordine delle word invertito.

Encoder 1

Low part: register 701

High part: register 700

Encoder 2

Low part: register 703

High part: register 702

Encoder 3

Low part: register 705

High part: register 704

Encoder 4

Low part: register 707

High part: register 706

9 Configurazione dispositivo con MyPixsys Lab

9.1 Connessione con il modulo MCM280

- 1 Se non è ancora stato fatto installare l'applicazione per desktop **MyPixsys Lab** scaricando il file di installazione dalla pagina del sito:
<https://www.pixsys.net/software-e-soluzioni/mypixsyslab>
nella sezione SOFTWARE
- 2 Avviare l'applicazione



- 3 Collegare il MCM280X alla rete del PC, ed accendere il dispositivo.
Il MCM280X ha IP predefinito **192.168.0.175**, ma **non** è necessario cambiare ip alla scheda di rete del PC per collegarsi.

Se il collegamento è stato eseguito correttamente comparirà il popup **Remote device available**



- 4 Selezionare la scheda di rete che si vuole utilizzare

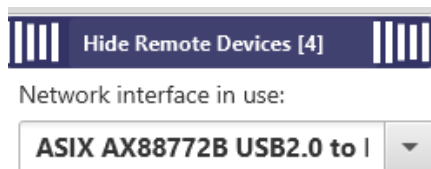

- 5 Aprendo il Popup vengono visualizzati i dispositivi presenti nella rete a cui è connesso il PC



- 6 Premere il pulsante **Connect** per aprire il menu di configurazione del modulo selezionato



- 7 Vengono visualizzati tutti i parametri dello strumento selezionato divisi per gruppi, premendo il tasto **READ** vengono letti e compilati tutti i dati e le configurazioni delle tabelle presenti nel modulo.

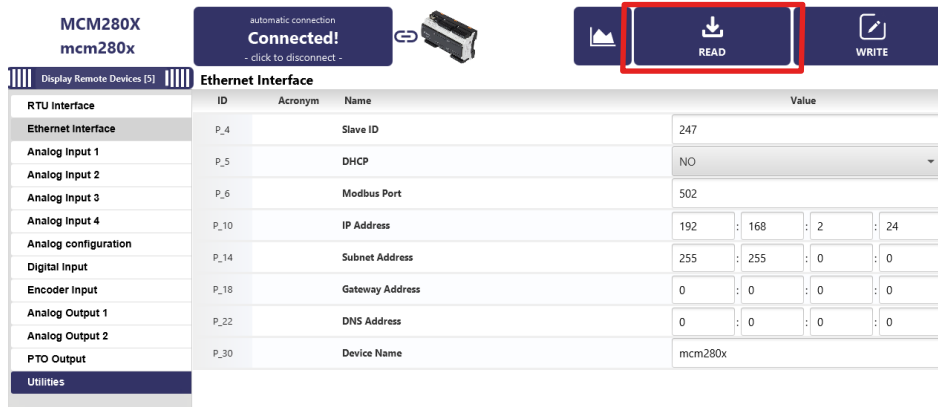

The screenshot shows the MCM280X software interface. At the top, there is a status bar with "MCM280X mcm280x" on the left, a "Connected!" indicator in the center, and "READ" and "WRITE" buttons on the right. The "READ" button is highlighted with a red box. Below the status bar, there is a sidebar with "Display Remote Devices (5)" and "Ethernet Interface" selected. The main area displays a table of parameters for the Ethernet Interface.

RTU Interface	ID	Acronym	Name	Value
Ethernet Interface	P_4		Slave ID	247
Analog Input 1	P_5		DHCP	NO
Analog Input 2	P_6		Modbus Port	502
Analog Input 3	P_10		IP Address	192 : 168 : 2 : 24
Analog configuration	P_14		Subnet Address	255 : 255 : 0 : 0
Digital Input	P_18		Gateway Address	0 : 0 : 0 : 0
Encoder Input	P_22		DNS Address	0 : 0 : 0 : 0
Analog Output 1	P_30		Device Name	mcm280x

9.2 Configurazione dei parametri

- 1 Configurare il dispositivo selezionando i valori dai menù a tendina o modificando i campi alfanumerici.
Vicino a tutti i parametri che vengono modificati si vedrà comparire la freccia ↻
Se si desidera riportare i parametri al valore iniziale premere la freccia ↺



The screenshot shows a configuration interface with two fields. The first field is "Frame format" with a dropdown menu showing "8,n,1". The second field is "Slave response waiting time" with a numeric input field showing "500" and "ms" next to it. A red arrow icon is visible next to the input field.

- 2 Dopo aver impostato tutti i parametri premere il pulsante **WRITE all**



Information!

Per rendere effettive le modifiche ai parametri o alle tabelle è sempre necessario riavviare il dispositivo

9.3 Salvataggio della configurazione del dispositivo

- 1 Una volta configurato il modulo, aprire il menu File e selezionare Save configuration

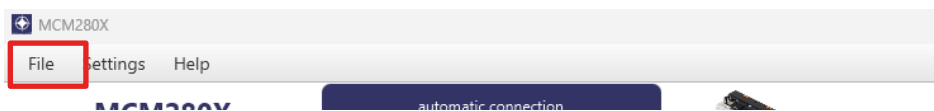

The screenshot shows the software interface with a menu bar at the top. The menu bar contains "File", "Settings", and "Help". The "File" menu is highlighted with a red box. Below the menu bar, there is a status bar with "MCM280X" and "automatic connection" visible.

- 2 Selezionare la directory dove salvare il file MCM280X.atr e premere **Salva**

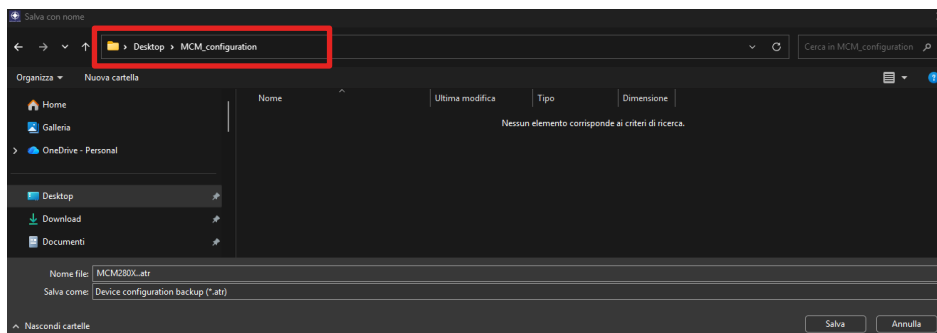

- 3 Il file generato potrà essere utilizzato per caricare la medesima configurazione in un nuovo dispositivo.

9.4 Caricamento della configurazione del dispositivo da file di Backup

- 1 Aprire il file .atr da menu File e selezionare **Import configuration**

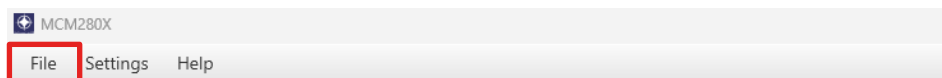

- 2 Connettersi al modulo da configurare



- 3 Premere il pulsante **WRITE all**



Read carefully the safety guidelines and programming instructions contained in this manual before using/connecting the device.

Prima di utilizzare il dispositivo leggere con attenzione le informazioni di sicurezza e settaggio contenute in questo manuale.



PIXSYS s.r.l.

www.pixsys.net

sales@pixsys.net - support@pixsys.net

online assistance: <http://forum.pixsys.net>

via Po, 16 I-30030

Mellaredo di Pianiga, VENEZIA (IT)

Tel +39 041 5190518



2300.10.396-RevC

150426